



Order

Number **06274026**

Date **06/27/2024**

Page **1**

609 Main Avenue
Moorhead, MN 56560
Phone: (218) 233-6104

Order Created: 06/27/2024

Sold To:
Customer # 491526
MIKE & BRENNA BIGWOOD
3608 11TH ST S
FARGO, ND 58104
Phone: (701) 360-4564 BRENNA

Ship To:
RED LEAF
7457 EAGLE POINT DR.
FARGO, ND 58104
Phone: (701) 360-4564

brenna.greenwood@gmail.com

SalesPerson TODDH	PO Number RED LEAF TO PAY	Tax Exempt #	Comment MATCHED LOWES PRICING FLOOR TO CEILING DOING VENT
Terms Net 30 Days	Ship Method Delivery		

Model Numbers				
Qty	Model Number	Model Description	Unit Amount	Extended
1	CVE28DP4NW2	"36"" Std-Depth\28.0 CuFt\4 Dr French Dr\Extrnl Di	\$3,499.00	\$3,499.00
1	C2S950P4MW2	"30"" S/\Dual Fuel RG\6 Burners\Sif Cln w/ Strm Cl	\$3,399.00	\$3,399.00
1	CDT858P4VW2	"SS TUB, TOP CONTROL, WASH 3RD RACK, SILVERWARE JE	\$999.00	\$999.00
1	CEB515P4NWM	CAFE 1,000W\1.5 CuFt\Conv\Scan-to-Cook	\$999.00	\$999.00
1	RC4-40-4	RANGE CORD 4 WIRE 4FT	\$20.00	\$20.00

Seller is not responsible for delays or lack of product due to causes beyond our control.

Purchaser agrees that Seller shall retain a purchase money security interest in the above merchandise until payment is made in full. There is no FINANCE CHARGE on accounts paid within 30 days of delivery. All accounts not paid within 30 days of delivery a FINANCE CHARGE is computer by a periodic rate of 1.5% per month or a minimum charge of 50 cents which is an Annual Percentage Rate of 18%. The finance charge is computer 30 days after delivery on the unpaid balance and each 30 day period thereafter. Prices quoted by salespersons are for normal situations and do not cover abnormal circumstances.

I/WE HAVE READ AND AGREE TO THE TERMS STATED ABOVE.
By _____ Buyers Signature Date _____

Summary	
Sub Total	\$8,916.00
Taxable Sub Total	\$8,916.00
Tax 7.5%	\$668.70
Total	\$9,584.70
Total Payments	
Amount Due	\$9,584.70
Total Payments	\$0.00
Amount Due	\$9,584.70

Café™ ENERGY STAR® 27.8 Cu. Ft. 4- Door French-Door Refrigerator

CVE28DP4NW2 / CVE28DP2NS1 / CVE28DP3ND1

CAFÉ

DISTINCT BY DESIGN™

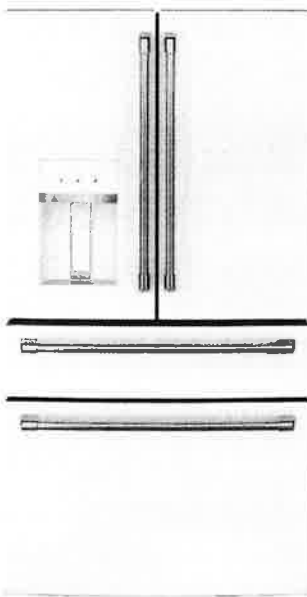

CVE28DP4NW2
Matte White with
Brushed Bronze handles



ALSO
AVAILABLE IN



CVE28DP2NS1
Stainless Steel
with Brushed
Stainless handles



CVE28DP3ND1
Matte Black
with Brushed
Stainless handles

FEATURES & BENEFITS

Enjoy the flexibility of a **Convertible Drawer with Soft Freeze** with settings as low as 23 degrees or as high as 42 degrees, and keep items organized with sliding glass dividers

Relish the bright, uniform light of an **LED light wall** that spans the back wall of the refrigerator, illuminating the fresh food section so every item is easy to find

Effortlessly fill containers with filtered water by simply pressing the **AutoFill** button which uses sensors to dispense the perfect amount every time

A **Humidity Control System** provides an environment for leafy green vegetables to last 2-1/2 times longer than standard vegetable drawers. (*Based on internal testing vs. similar size vegetable drawers with humidity controls from a leading competitor.)

Easily pull out a slim, **full-width tray** to accommodate gourmet pizzas and other frozen, uniquely shaped items

Receive alerts on your smart device whenever your refrigerator's internal temperature dips below normal, thanks to **built-in WiFi connectivity** that helps you keep foods party-platter ready

From produce to packaged goods, keep any food fresh with **TwinChill™ evaporators** that create separate climates in the fresh food and freezer sections

Spend more time filling and less time fumbling thanks to the **Integrated Dispenser Design**, which senses your proximity and automatically illuminates, so you never have to compromise on function and fashion

APPEARANCE

Exterior design	Bowed flat top
Handle	Café™
Handle design	Café Pro
Hidden door hinge(s)	Yes

FEATURES

Configuration	French-door & Double drawer
WiFi connect	Built-in
Connected capabilities	Amazon Alexa; The Google Assistant; IFTTT
Temperature management features	Multiflow air system
Temperature management system	TwinChill™ evaporators
Defrost type	Frost Guard
Control type	Electronic temperature controls
Dispenser	Large stainless steel; Cubes, crushed ice and chilled water
Dispenser features	Hands-free AutoFill; Door alarm; LED dispenser light; Water filter indicator light
Icemaker	Space saving ice
Water filtration	GE water filtration 6 month; XWF; Water filter indicator light
Filter location	Left wall
Fresh food cabinet drawers	2 total; 2 adjustable humidity drawers
Fresh food cabinet shelves	4 glass split; 1 Quick Space shelf
Fresh food door bins	6 total; 2 with gallon storage; 1 adjustable
Fresh food door features	Dairy compartment
Fresh food features	LED light wall; Deli pan
Freezer door bins	3 (2 adjustable tilt-out)
Freezer storage baskets	2 full-width
Freezer features	Interior lighting - LED; Freezer drawer with full-extension slides
Exterior style	Free-standing
Leveling system	2 point front adjustable
Performance features	Easily removable door gaskets; Sabbath Mode capable
Center drawer features	Convertible drawer; 6 temperature settings (Soft Freeze, Meats, Beverages, Snacks, Wine, Lock); 2 Tuck Away glass dividers; Full-extension slides

CAPACITY

Total capacity (cubic feet)	27.8 cu. ft.
Fresh food capacity	15.62 cu. ft.
Freezer capacity	8.57 cu. ft.
Convertible drawer capacity	3.62 cu. ft.

WEIGHTS & DIMENSIONS

Overall depth	36-3/4 in.
Overall height	69-7/8 in.
Overall width	35-5/8 in.
Case depth without door	29-3/8 in.
Depth with door open 90°	48-3/8 in.
Depth without handle	34-1/4 in.
Height to top of hinge	69-3/4 in.
Height to top of case	68-5/8 in.
Width w/door open 90 degrees incl. handle	44-7/8 in.
Back air clearances	2 in.
Side air clearances	1/8 in.
Top air clearances	1 in.
Approximate shipping weight	408 lb.
Net weight	375 lb.

Café™ ENERGY STAR® 27.8 Cu. Ft. 4- Door French-Door Refrigerator

CVE28DP4NW2 / CVE28DP2NS1 / CVE28DP3ND1



DISTINCT BY DESIGN™

WARRANTY

Parts warranty	Limited 1-year entire appliance; Limited 5-year sealed refrigerating system
Labor warranty	Limited 1-year entire appliance; Limited 5-year sealed refrigerating system
Warranty notes	See written warranty for full details

DIMENSIONS

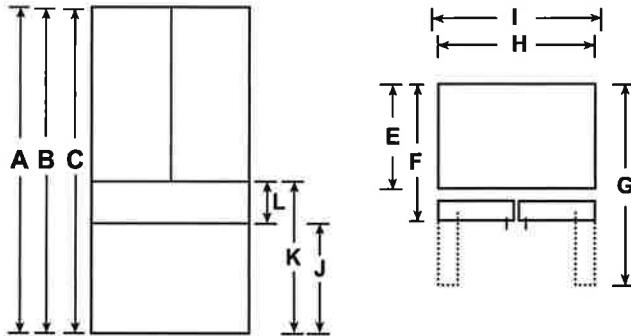

Overall Dimensions	Value
A - Overall Height to top of door (in)	69 7/8
B - Height to top of hinge cover (in)	69 3/4
C - Height to top of case (in)	68 5/8
D - Hinge Cover Depth from Case Flange (in)	6
E - Case Depth without door (in)	29 3/8
F - Case Depth without Door Handle (in)	34 1/4
G - Depth with FF Door open 90 deg (in)	48 3/8
H - Case Width (in)	35 5/8
I - Width with door open 90 deg including handle (in)	44 7/8
J - Top endcap of FZ drawer to floor (in)	24 1/2
K - Top endcap of Middle drawer to floor (in)	33 1/2
L - End cap to End cap height of middle drawer (in)	8 5/8

ADDITIONAL ACCESSORIES



CXQB4H4PNBZ
Brushed Bronze
4 handles
(Standard on Matte White)



CXQB4H4PNSS
Brushed Stainless
4 handles
(Standard on Matte Black and Stainless Steel)



CXQB4H4PNBT
Brushed Black
4 handles



CXQB4H4PNCU
Brushed Copper
4 handles



CXQB4H4PNCG
Brushed Brass
4 handles



CXQB4H4PNFB
Flat Black
4 handles

Café™ 30" Slide-In Front Control Dual-Fuel Double Oven with Convection Range

C2S950P4MW2 / C2S950P3MD1 / C2S950P2MS1

CAFÉ

DISTINCT BY DESIGN™

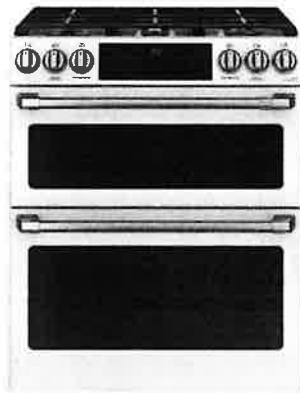

ALSO AVAILABLE IN



C2S950P2MS1
Stainless Steel with Brushed Stainless handles and knobs



C2S950P3MD1
Matte Black with Brushed Stainless handles and knobs



FEATURES & BENEFITS

Expansive six-burner cooktop helps you entertain with ease - Entertaining for large groups is easy with the industry's first six burner, edge-to-edge cooktop that can accommodate cookware of all sizes and a cast-iron integrated griddle that provides enough room to perfectly flip crab cakes, arepas and other crowd favorites

An attractive appearance at all times - Every detail of your kitchen is designed to delight, thanks to a sleek backlit glass touch control panel that visually disappears when not in use and wakes up when prompted

Share favorite creations with your favorite people - Create an unforgettable dinner, using a 21K tri-ring burner to do everything from searing scallops to simmering a lemon caper white wine sauce and a 15K power boil burner to boil water quickly for al dente angel hair pasta

Everything you need for unforgettable results - Get the precision you need to pull off a multi-course dinner party with this 7.0 cu. ft. double oven dual fuel range, which boasts a gas-powered cooktop for precise heat control and electric True European Convection with Precise Air in the oven for even baking results.

Never scrub, smooth-glide racks - Easily remove heavy dishes with a roller rack that is specially designed to glide smoothly and stay in the oven during the self-clean cycle, so you never have to handle cumbersome racks again

Create a look that matches your personal style - Select any combination of premium finishes and hardware options to create a stunning look customized to any owner's taste

Allow your appliances to interact with one another - Create a chef-like experience with Chef Connect, which can synchronize your appliance clocks and surface lights and vent when a range burner is in use, and even your microwave and range clocks

Prepare foods to perfect doneness - Get roasts and meats just right with a temperature probe that lets you monitor progress without opening the oven door

WIFI-ENABLED FEATURES

Built-In WiFi, Powered by SmartHQ App - Manage all aspects of your kitchen with the help of the SmartHQ™ App or your voice assistant

Personalized Features + Upgrades - Usher in the latest features by downloading cooking upgrades right to your oven, putting Air Fry and more in your repertoire

No-Preheat Air Fry - Cook healthier, crispier versions of your favorite foods in less time, thanks to an air fryer right in your oven that doesn't require preheating, a basket or a special tray

FEATURES

Configuration	Double Oven Range
Cooking System	True European Precise Air Reversing
Cooking Technology	Traditional Upper; Convection Lower
Oven Cleaning Type	Self-Clean with Steam Clean Option
Burner - Left Front	21,000 BTU Tri-ring Burner
Burner - Left Rear	5,000 BTU Precise Simmer
Burner - Right Front	15,000 BTU
Burner - Right Rear	12,000 BTU
Burner - Center	9,500 BTU Front / 9,500 BTU Rear
Cooktop Burner Type	Sealed
	Deep Recessed
Cooktop Surface	Stainless Steel
Dishwasher Safe Knobs	Yes
Control Location	Front controls
Control Type	Backlit; Glass Touch
Valves (Degree of Turn)	270
	No-Preheat Air Fry
	Remote Control
	Remote Notifications
	Scan-to-Cook (Oven)
	Timers (App)
	Clock Sync
WiFi Enabled Features	Voice Assistants (Google and Alexa)
	Audible Preheat Signal
	Auto Oven Shut-Off
	Auto Self Clean
	Automatic Oven Timer (Time Bake)
	Sabbath Mode
	Chef Connect
	Control Lock Capability
	Delay Bake Option (Time Bake)
	Delay Clean Option
	Digipad Numeric Entry
	Electronic Clock and Timer
	Front Controls
	In-Oven Broiling
	Self-Clean Cool Down
	Time Display
Oven Control Features	Temperature Probe
	Baked Goods - Both Ovens
	Convection Bake
	Convection Roast
	Frozen Pizza Multi Rack - Lower Oven
	Frozen Pizza Single Rack - Lower Oven (No Preheat)
	Frozen Snacks Multi Rack - Lower Oven
	Frozen Snacks Single Rack - Lower Oven (No Preheat)
	Proof (Lower Oven)
Oven Cooking Modes	Warming (Both Ovens)
Oven Features	6-Pass Broil Element; 8-Pass Broil Element
Cooktop Burner Grate Features	Heavy-Cast Edge-to-Edge Grates
Cooktop Burner Grate Material	Cast-Iron
Cleaning Time	Variable with Delay Clean Option
Self-Clean Oven Door Lock	Automatic
Oven Rack Features	1 Roller Rack (Upper); 2 Self-Clean Flat Oven Racks (Lower); 6 Rack Positions
Fuel Type	240V Electric and Natural Gas
Ignition System	Electronic w/Auto Reignition
Leveling System	4 Leveling Legs
Style	Commercial
Oven Interior	2 Oven Interior Lights; Hidden Bake; Black
	Amazon Alexa
	DiGiorno
	Drop
	IFTTT
	Innit
	Sonos
Connected Capabilities	The Google Assistant
WiFi Connect	Built-In
Lower Oven Features	Dual element bake

CAPACITY

Total Capacity (cubic feet)	7.0 cu ft
Capacity (Cu. Ft.)	2.7 Upper / 4.3 Lower

Café™ 30" Slide-In Front Control Dual-Fuel Double Oven with Convection Range

C2S950P4MW2 / C2S950P3MD1 / C2S950P2MS1

CAFÉ

DISTINCT BY DESIGN™

ACCESSORIES

Grates	Included Center Grate
Grill	Optional; Integrated Cast Iron; JXCGRILL1
LP Conversion Kit	Included
Trim Kit	Optional; JXFILLR1DD; JXFILLR1SS
Griddle	Included; Integrated Cast Iron

WEIGHTS & DIMENSIONS

Cabinet Opening	30 in
Depth with Door Open	43-7/8 in
Approximate Shipping Weight	291 lb
Net Weight	271 lb
Height to Top of Rear Vent Trim	37-3/8 in
Overall Height	37-3/8 in
Height to Cooking Surface (in.)	36-1/4 +/- 1/4
Overall Width	29-7/8 in
Cabinet Width	30 in
Overall Depth	29-1/2 in
Depth Without Handle	26-7/8 in
Oven Interior Dimensions (W x H x D) (in.)	24 x 10-1/8 x 19-1/8 - Upper 24 x 15 x 20-5/8 - Lower

APPEARANCE

Cooktop Burner Grate Color	Matte Black
Installation	Power Cord Not Included
Oven Door Features	Big Clear View Oven Window
Handle	Professional Style Customizable Consumer Removable
Handle Design	Café

POWER / RATINGS

Amp Rating at 208V	30
Amp Rating at 240V	30
Convection Wattage	2500W
Top Burner BTU Rating - LP (000's BTU's)	(1) 18.0 Tri-Ring; (1) 15.0; (1) 12.0; (2) 9.5; (1) 5.0
Top Burner BTU Rating - Nat. Gas (000's BTU's)	(1) 21.0 Tri-Ring; (1) 15.0; (1) 12.0; (2) 9.5; (1) 5.0
Volts/Hertz/Amps	208/240V; 60Hz; 30A
Power Connection	Power Cord - Not Included
Bake Wattage	2650W Upper / 2650W Lower
Broiler Wattage	3000W Upper / 3600W Lower

WARRANTY

Parts warranty	Limited 1-year entire appliance
Labor warranty	Limited 1-year entire appliance

DIMENSIONS

Electrical Requirements:

240v/208v; 60Hz, 30A

Installation information:

Before installing, consult installation instructions packed with product for current dimensional data.

For all installations, install the required rear trim to back of range with 4 screws provided.

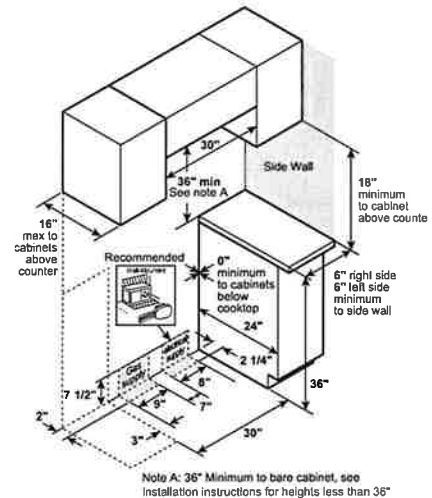
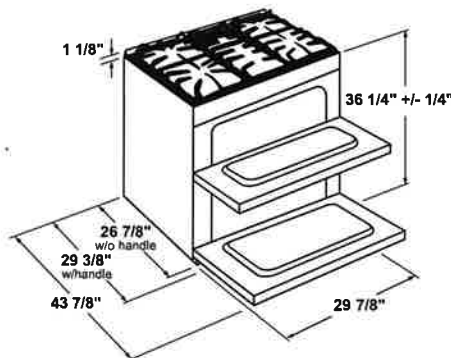

ADDITIONAL ACCESSORIES



CXFCGHKPMBZ
Brushed Bronze
2 handles; 6 knobs
(Standard on Matte White)



CXFCGHKPMSS
Brushed Stainless
2 handles; 6 knobs
(Standard on Matte Black)



CXFCGHKPMBT
Brushed Black
2 handles; 6 knobs



CXFCGHKPMCU
Brushed Copper
2 handles; 6 knobs

Café™ CustomFit Stainless Interior Built-In Dishwasher with Hidden Controls

CDT858P4VW2/CDT858P3VD1/CDT858P2VS1

CAFÉ

DISTINCT BY DESIGN™

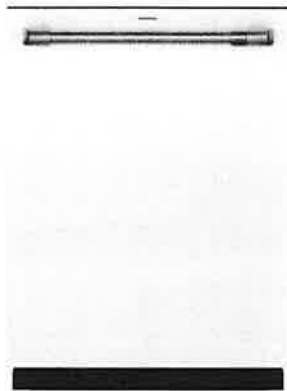

ALSO AVAILABLE IN



CDT858P3VD1
Matte Black with
Brushed Stainless
handles



CDT858P2VS1
Fingerprint Resistant
Stainless Steel with
Brushed Stainless handles

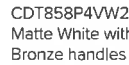

CDT858P4VW2
Matte White with Brushed
Bronze handles



FEATURES & BENEFITS

CustomFit Top Rack with Ultra Wash – Load your way in this dishwasher with a customizable top rack. The CustomFit Top Rack can be configured to maximize flexibility. In addition, the UltraWash Zone uses powerful jets to target stuck-on food on silverware, spatulas, ramekins and lids.

CustomFit Basket with Ultra Wash – Load more than just silverware in this flexible basket with dedicated wash jets below. The CustomFit Basket holds all your silverware, 9" tall stemware and reusable straws, so items that were hand-washed before can safely be washed in the dishwasher.

CustomFit Lid Caddy – Cup lids and blender blades can easily dry thanks to the CustomFit Lid Caddy. It is designed to hold items at the perfect position for cleaning and restricts water from pooling, so pieces come out clean and dry after every wash.

Ultra Wash & Dual Convection Ultra Dry – Expect precision cleaning and superior dryness on fine china, dinnerware and plastics in this ultra-wash and dry dishwasher. Exceptional features like Variable-Pressure Jets and Dual-Convection Ultra Dry offer great results with every cycle.

Customizable Dishwasher Handles – Choose from six unique Café handle finishes to complement the rest of your kitchen thanks to this dishwasher with customizable hardware.

4 Bottle Wash Jets – This dishwasher with 4 bottle wash jets ensures a deep clean for tall items, narrow glasses, jars and more. In the upper rack, each of the jets directs water and detergent inside to effectively wash hard-to-reach areas.

Smart Features Powered by SmartHQ™ – Built-in WiFi and the SmartHQ™ app make it easy to control and monitor your smart dishwasher from anywhere. You can also conveniently access the latest features like Favorites, which allows you to access your favorite cycles with a single button.

Smart Assist – Smart Assist makes it simple for you to unlock optimal wash and dry performance. Innovative dishwasher sensors and intelligent machine learning enhance and improve cycles over time.

Smooth-Glide Adjustable Middle Rack – Load your dishwasher your way thanks to an adjustable middle rack. Easily move it up and down to fit bottles, large platters and other items as tall as 10.5".

Presoak + Sanitize – Save time with a high-temperature cycle that steams and sanitizes. Loosen tough soils before the wash cycle begins without the need to pre-rinse or soak. Plus, a sanitization cycle reduces 99.999% of bacteria on dishes.

Silverware Wash – Powerful jets in the top rack and CustomFit basket work in unison using targeted washing action to clean even the most stuck-on foods from silverware, cooking utensils and more.

Middle and Lower Rack Fold-Down Tines – Two rows of adjustable tines in both the middle and lower rack allow you to load the way you want. 16 different tine positions offer the ultimate customization to fit all of your items.

Wash Zones – Wash a true half load in the upper or lower rack whenever you need to in this dishwasher with loading flexibility. Just choose your wash zone: upper or lower. The feature works in combination with most cycles, saving you time and conserving energy.

Active Flood Protect – Active Flood Protect prevents potential overflows for greater peace of mind. It works by using a water leak detector to sense when water is too high, pumping it out until a safe level is reached.

Flush Installation – Cabinet-depth flush installation ensures your dishwasher blends in with the design of your kitchen without sacrificing space for dishes inside.

Piranha™ Hard Food Disposer – The Piranha™ Hard Food Disposer lets you use your dishwasher without pre-rinsing. Its stainless steel impellers rotate to pulverize food particles and an anti-jamming design make sure wash arms stay unclogged.

44 dBA Dishwasher – Enjoy a peaceful kitchen while delivering a powerful wash thanks to this super-silent 44 dBA dishwasher.

FEATURES

Style	Built-In
Tub and Door Liner	Stainless Steel
Tub Type	Tall Tub
Control Type	Top Controls; Cap Touch Controls; 8 Touchpads
Dishwasher Control Features	Audible End-of-Cycle Signal; Cycle Countdown with Bi-Color LED Status Light on door; Cycle Progress Indicators: Clean/Sanitized/Smart Assist/WiFi/Remote Enabled; Last Cycle Memory; Fingerprint Resistant
Wash System	3-Level; 800 Series
Wash System Features	90+ Spray Jet Wash System; Automatic HotStart; Automatic Temperature Control; Bottle Jets (4); Deep Clean Silverware Jets; Hard Food Disposer with removable filter; Lower Wash Arm; Middle Wash Arm; Variable Speed Dual Pumps and Motors
Sensor	Clean Sensor
Wash Arms	3rd Rack; 4 Wash Levels; Bottle Jets; Deep Clean Silverware Jets; Lower; Middle; Upper; CustomFit Basket with Ultra Wash Jets
Water Filtration System	100% Filtration with Hard Food Disposer and Removable Filter
Dispenser	Rinse Aid with Indicator and Adjustment
Number of Cycles	6
Dishwasher Cycles	Auto Wash; Cascade Platinum Plus (on app); Cookware; Express; Gentle; Normal
Number of Options	15
Dishwasher Options	1/2 Load (on app); Bottle Wash (on app); Delay Start 1-12 Hr.; Favorites (on app); Heated Dry Off; Hi-Temp Wash; Lock Controls; Normal Dry; Presoak + Sanitize (Certified to NSF Standard 184); Sabbath Mode; Silverware Wash; Start/Cancel; Ultra Dry; WiFi/Remote Enabled; Favorites on Machine and App
Rack Features	Adjustable Upper Rack; Ball-Tipped Tines; Cafe Flex Silverware Basket; Full Extension Slides – Middle; CustomFit Lid Caddy
Racking Material	Nylon
Rack Color	Black Pearl
Number of Place Settings	Up to 16
Upper Rack	1 Rack handle; 1/2 fixed tines, 1/2 fold down tines; Ball-Tip Tines; Fixed tines with Bottle Jets; Lid Manager; Premium Height Adjustable; Smooth Glide Middle Rack
Lower Rack	Heated Dry - Ultra/Normal/Off; Multi-Wattage Wash & Dry Element; Ultra Dry
Additional Protection	Active Flood Protect; Leak Defense with Active Flood Protect
Dishwasher Drying Features	Dual Convection Ultra Dry; Heated Dry – Ultra/Normal/Off; Multi-Wattage Wash & Dry Element; Dual Fan Assist
Cutlery Tray	CustomFit Top Rack with Ultra Wash
Leveling System	4 Leveling Legs
Latch	Pull Handle
WiFi Connect	Built-In
Exterior Style	Traditional

ECONOMICAL/QUIET

Quiet Package	44 dBA
Quiet Features	Quiet Water Valve; Sealed Toe Kick; Tub Collar Trim
Motor Type	Variable Speed
Outer Wrap	Full-Wrap Blanket; Bitumen
Door Insulation	Insulation; Mastic

WEIGHTS & DIMENSIONS

Cabinet Width	24 in
Approximate Shipping Weight	137 lb
Net Weight	124 lb
Overall Height	34 in
Height w/Legs Retracted - Minimum Height	33-3/8 in
Height w/Legs Extended - Maximum Height	34-5/8 in
Overall Depth	24 in
Overall Width	23-3/4 in

APPEARANCE

Door Style	Long Door with Top Controls
Installation	Side Installation or Top Installation Included; Built-Up Floor Capable; Flush Cabinet Installation
Door Appearance	Full-length flat door

Café™ CustomFit Stainless Interior Built-In Dishwasher with Hidden Controls

CDT858P4VW2/CDT858P3VD1/CDT858P2VS1

CAFÉ

DISTINCT BY DESIGN™

TECHNICAL DETAILS

Calrod Heater Watts	1200/400
Power Connection	Optional cord kit (GPFCORD - WX09X70910, WX09X70911)
Volts/Hertz/Amps	120 V; 60 Hz; 7.8 A

WARRANTY

Parts warranty	Limited 1-year entire appliance
Labor warranty	Limited 1-year entire appliance
Warranty notes	See written warranty for full details

DIMENSIONS

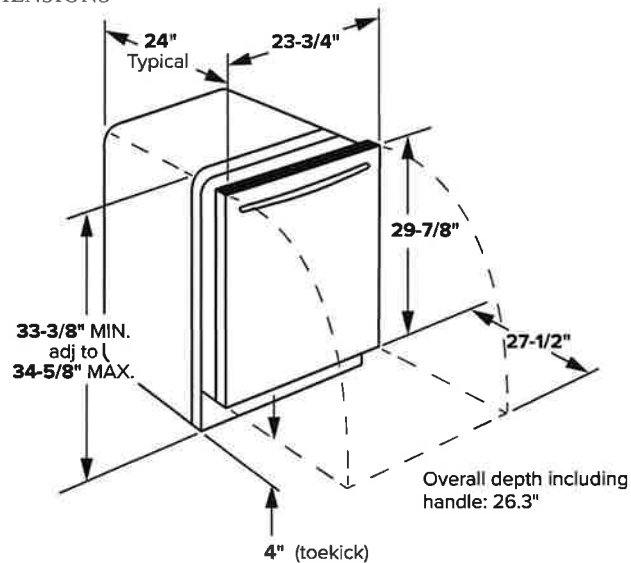

INSTALLATION DIMENSIONS

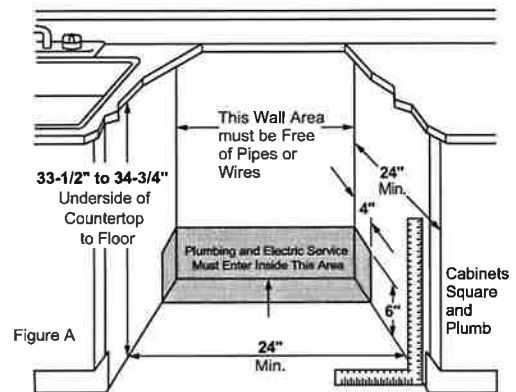

ADDITIONAL ACCESSORIES



CXADTH1PVBT ACC
Brushed Black
Handle Kit



CXADTH1PVBZ ACC
Brushed Bronze
Handle Kit
(Standard on
Matte White)



CXADTH1PVCU ACC
Brushed Copper
Handle Kit



CXADTH1PVSS ACC
Brushed SS
Handle Kit
(Standard on
Matte Black and
Stainless Steel)



CXADTH1PVCG ACC
Brushed Brass
Handle Kit



CXADTH1PVFB ACC
Flat Black
Handle Kit

Café™ 1.5 Cu. Ft. Countertop Convection/Smart Microwave Oven

CEB515P4NWM / CEB515P3NDS / CEB515P2NSS

CAFÉ

DISTINCT BY DESIGN™

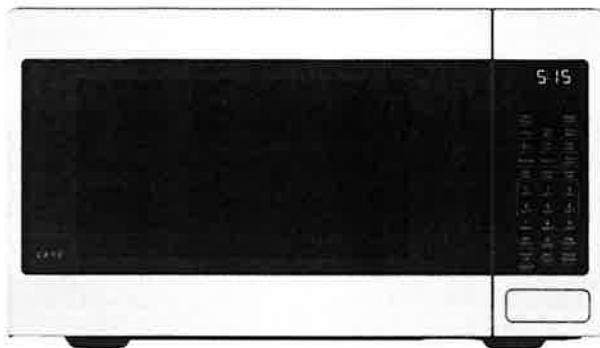

ALSO AVAILABLE IN



CEB515P2NSS
Stainless Steel



CEB515P3NDS
Matte Black

FEATURES & BENEFITS

Enjoy total control in the kitchen and beyond - Control your oven with your smart device or simply your voice using WiFi Connect

Achieve gourmet results with just a scan - Delegate simple cooking tasks to family members with Scan-to-Cook Technology. With just the scan of a barcode, the microwave automatically adjusts cook settings based on package instructions.

A microwave that's as versatile as you are - Achieve crisp, golden brown results with a convection cooking setting and a special rack that allows air to circulate around foods for even heat distribution

Say goodbye to guesswork - Enjoy consistently delicious results with sensor cooking controls that automatically adjust the time and power

Get that just-cooked quality anytime - Even late-arriving guests can enjoy delicious results thanks to a warming oven that keeps foods ready to serve

Let the cooking take care of itself - Take the guesswork out of preparing your favorite foods with an auto bake/auto roast feature that uses preprogrammed cooking times and temperatures

Enjoy design flexibility in your kitchen - Create more room on the countertop for meal prep with a built-in capable microwave and matching trim kit

Nice and roomy - Entertain with confidence with 1.5 cu. ft. capacity that can handle more of your favorite foods

APPEARANCE

Installation	Countertop; Built-In
--------------	----------------------

FEATURES

Cooking System	Turntable
Cooking Technology	Microwave/Convection
Electronic Digital Display with Clock	Yes (LED)
Express Cook	Instant-On 1-6
Instant On Controls	Yes
Microwave Watts (IEC-705)	1000W
Power Levels	10
Rack Type	2 Removable Oven Racks - Pedestal
Sound Volume Control	On/Off
Timer (On/Off)	Yes
Turntable	Glass Recessed
Turntable Size	13.5 in
Scrolling Display with Help	Yes
Convection Cooking Controls	Bake; Roast
Microwave Sensor Cooking Controls	Popcorn; Beverage; Reheat; Cook
Control Features	Control Lock; Cook Time; Clock; Timer; Add 30 Seconds; Mute; Warm; Convection Bake; Convection Roast; Combination Auto Cook; Auto Bake; Auto Roast; Auto & Time Defrost; Display On/Off; Broil; Scan-to-Cook; Voice Assistant Compatible
Microwave Oven Interior	Stainless Steel
Combination Cooking Controls	Combination Cook
WiFi Connect	Built-In

CAPACITY

Total Capacity (cubic feet)	1.5 cu ft
Unit Capacity	Family-Size

TECHNICAL DETAILS

Electrical Input - 120V Amperage	13.0
Electrical Input - 120V Watts	1500
Frequency (MHz)	2450
Volts/Hertz	120V; 60Hz

WEIGHTS & DIMENSIONS

Approximate Shipping Weight	44 lb
Cavity (W x H x D)	15-1/2 x 10-7/8 x 15-1/2
Depth with Door Open 90°	36-7/16 in
Net Weight	38 lb
Overall Depth	20 in
Overall Height	13 in
Overall Width	21-3/4 in

WARRANTY

Parts Warranty	Limited 1-year entire appliance
Labor Warranty	Limited 1-year entire appliance
Warranty Notes	See written warranty for full details

Café™ 1.5 Cu. Ft. Countertop Convection/Smart Microwave Oven

CEB515P4NWM / CEB515P3NDS / CEB515P2NSS



DIMENSIONS AND INSTALLATION INFORMATION

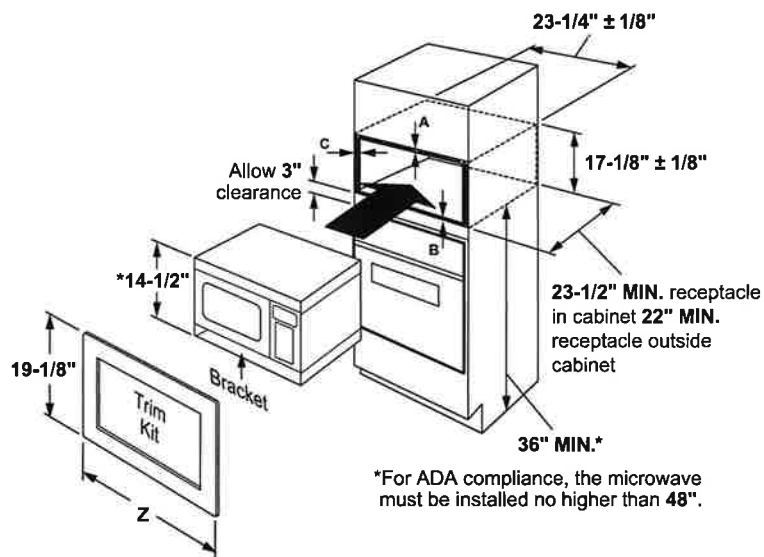
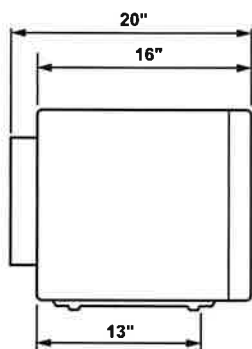
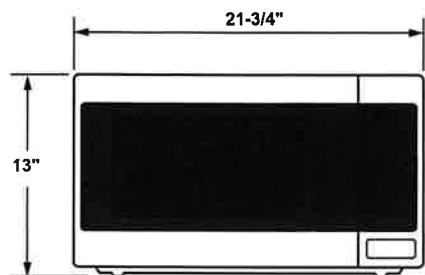

*For ADA compliance, the microwave must be installed no higher than 48\".

EXTERIOR DIMENSIONS (IN INCHES)

Height	13"
Width	21-3/4"
Depth	16"
Depth including bumpout	20"
Depth from back of case to front legs	13"

CABINET OVERLAP REQUIREMENTS

	30"	27"
A - Overlap of trim kit over top of cabinet	1"	1"
B - Overlap of trim kit over bottom of cabinet	1"	1"
C - Overlap of trim kit over sides of cabinet	3-5/16"	1-7/8"

NOTE: Allow an additional inch of clearance beyond trim kit frame on all sides.

OPTIONAL ACCESSORY TRIM KITS (AVAILABLE AT ADDITIONAL COST)

For a custom built-in appearance, these kits allow built-in installation of the countertop microwave oven into a wall or cabinet alone and are U.L. approved for installation over a GE single electric wall oven. These kits should not be installed over a gas wall oven.

Note: 120V, 60-cycle, grounded power receptacle location optional on back within cabinet opening.

Installation Information: This information is not intended to be used for installing unit described. Before installing, consult installation instructions packed with product/kit for current dimensional data.

*Height of product when installed with kit rail and bottom duct: 14-1/2"

ACCESSORY TRIM KITS "Z" MAX HEIGHT TRIM KITS

ACCESSORY TRIM KITS	"Z"	MAX HEIGHT	TRIM KITS
30" Deluxe	29-3/4"	19-1/8"	CX153P3MDS /CX153P4MWM/ CX153P2MSS
27" Deluxe	26-7/8"	19-1/8"	CX152P3MDS /CX152P4MWM/ CX152P2MSS