



Order

Number **08234031**

609 Main Avenue
Moorhead, MN 56560
Phone: (218) 233-6104

Order Created: 08/23/2024

Date **08/23/2024**

Page **1**

Sold To:

Customer # **275964**
JON KUNGEL
4250 BRISTLECONE LOOP
FARGO, ND 58104
Phone: (701) 371-3270 JON

Ship To:

JON KUNGEL
4250 BRISTLECONE LOOP
RED LEAF
FARGO, ND 58104
Phone: (701) 371-3270 JON

kungeljon@gmail.com

SalesPerson STEVE	PO Number kungeljon@gmail.com	Tax Exempt #	Comment INCLUDES DELIV - DROP OFF BUILT INS NO HKUP OF GAS - N/G - INSTALL MW
Terms Net 30 Days	Ship Method Delivery		

Model Numbers

Qty	Model Number	Model Description	Unit Amount	Extended
1	GFE26JEMDS	"36"" Std-Depth\26.0 CuFt\3 Dr French\Extrnl Disp	\$1,799.00	\$1,799.00
1	GG600AVDS	GE@ 30" Slide-In Front-Control Convection - Gas - Air Fry	\$1,099.00	\$1,099.00
1	GDT670SFVDS	GE 24" Built In Dishwasherr	\$649.00	\$649.00
1	CWL112P3RD5	CAFE DRAWER M/W 1,000W\Sensor\Time Defrost	\$1,599.00	\$1,599.00
1	JVW5301FJDS	"30"" Chimney Hood\350 CFM\Halogen Lighting\Conver	\$619.00	\$619.00
1	UXDC53FJDS	10 Ft Duct Cover\Black Slate	\$139.00	\$139.00
1	GF655SPVDS	GE 5.0 cu ft Front Load Washer	\$829.00	\$829.00
1	GFD65ESPVDS	GE 7.8 cu ft Front Load Dryer	\$829.00	\$829.00
1	GFP1528PTDS	PROFILE PEDESTAL	\$299.00	\$299.00
1	GFP1528PTDS	PROFILE PEDESTAL	\$299.00	\$299.00
1	DC4-30-5	DRYER CORD 4 WIRE 5FT	\$20.00	\$20.00

Seller is not responsible for delays or lack of product due to causes beyond our control.

Purchaser agrees that Seller shall retain a purchase money security interest in the above merchandise until payment is made in full. There is no FINANCE CHARGE on accounts paid within 30 days of delivery. All accounts not paid within 30 days of delivery a FINANCE CHARGE is computer by a periodic rate of 1.5% per month or a minimum charge of 50 cents which is an Annual Percentage Rate of 18%. The finance charge is computer 30 days after delivery on the unpaid balance and each 30 day period thereafter. Prices quoted by salespersons are for normal situations and do not cover abnormal circumstances.

I/WE HAVE READ AND AGREE TO THE TERMS STATED ABOVE.
By _____ Buyers Signature Date _____

Summary

Sub Total	\$8,180.00
Taxable Sub Total	\$8,180.00
Tax 7.5%	\$613.50
Total	\$8,793.50
Total Payments	
Amount Due	\$8,793.50
Total Payments	\$0.00
Amount Due	\$8,793.50



Model#: GFE26JEMDS

GE® ENERGY STAR® 25.7 Cu. Ft. French-Door Refrigerator

Approx Dimensions (HxWxD):
69 7/8 H x 35 3/4 W x 35 7/8 D

- 25.6 cu. ft. capacity-Easily store large or bulk food items with three full-width shelves and large capacity
- Space-saving icemaker-Located on the door with integrated bins to create more usable storage space
- LED lighting-Find exactly what you've been looking for under crisp, clear lighting
- External controls with actual temperature display, child lock and door alarm-Eliminates the guesswork in setting refrigerator temperatures; conveniently displayed on the dispenser
- Spill-proof shelves-A variety of shelf configurations provide additional options for food storage
- Two humidity-controlled drawers and full-width drawer>Create the right environment for keeping fruits and vegetables fresh, while easily storing wider items like a party platter or a sheet cake
- Quick Space shelf-Quickly slides out of the way to make room for tall items

Warranty Information:

- Warranty Notes: See written warranty for full details
- Labor Warranty: Limited 1-year entire appliance
- Parts Warranty: Limited 1-year entire appliance





Model#: GGS600AVDS

GE® 30" Slide-In Front-Control Convection Gas Range with No Preheat Air Fry and EasyWash™ Oven Tray

Approx Dimensions (HxWxD):

37 1/8 H x 30 W x 28 5/8 D

- EasyWash™ Oven Tray-Oven cleaning is easier than ever with the EasyWash™ Oven Tray. This enameled tray is easily removed and rinsed clean in the sink or, for bigger messes, guaranteed to fit in all GE Appliances dishwashers.
- Built-In WiFi-Built-in Wifi and the SmartHQ app gives you oven control functions like remote preheat, the ability to monitor and change oven temperature, turn off your oven and more! [See details](#)
- No Preheat Air Fry-No preheat air frying is a great way to get crispier versions of your favorite foods in less time.
- No Preheat Fresh Reheat-Perfect for leftovers from the night before, the to-go box from your favorite restaurant or refreshing soggy fries to ideal crispiness, this no preheat mode saves you time and delivers flawless results.
- No Preheat Pizza-Specifically designed to cook your frozen pizza, this no preheat option is a time saver and a great way to get dinner on the table fast.
- Express Preheat-Get food on the table quicker thanks to a fast preheat oven. In just 7 minutes*, you have a perfectly preheated oven. *Preheats oven in just 7 minutes, bake mode to preheat beep, 350 degrees, one standard rack.
- Slide-In Range-Easily upgrade your kitchen with this new slide-in range that is guaranteed to fit into your existing space.

Warranty Information:

- Parts Warranty: Limited 1-year entire appliance
- Labor Warranty: Limited 1-year entire appliance
- Warranty Notes: See written warranty for full details

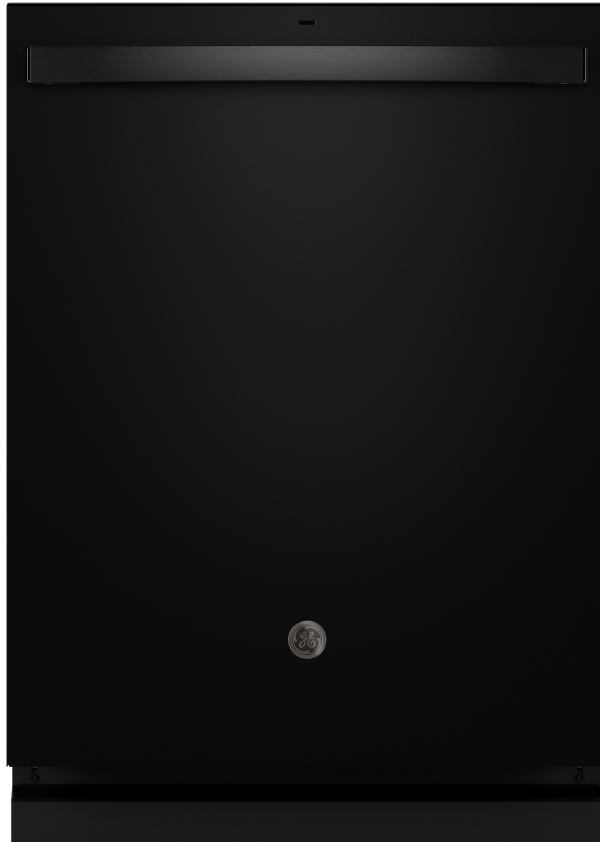

Model#: GDT670SFVDS

GE® ENERGY STAR® Top Control with Stainless Steel Interior Dishwasher with Sanitize Cycle

Approx Dimensions (HxWxD):

34 H x 23 3/4 W x 24 D

- Dry Boost™ Technology-Dry Boost™ Technology outperforms standard heated-dry dishwashers by getting hard-to-dry items like plastics up to 3 times drier when compared to heated dry.
- Third Rack with Removable Silverware Caddy-The versatile Third Rack was redesigned to load more than just silverware with additional space for unique items.
- Deep Clean Silverware Jets-A system of 40 deep-cleaning silverware jets blasts the silverware basket from the bottom up, removing all stuck-on food for sparkling results.
- 4 Bottle Wash Jets-Ensure a deep clean for tall items, narrow glasses, jars and more thanks to this dishwasher with bottle jets. 4 powerful jets direct water and detergent inside to effectively wash hard-to-reach areas.
- Smooth-Glide Upper Rack-This dishwasher with a smooth-glide rack makes loading and unloading smooth and simple. It easily extends on stainless steel ball bearings, so you can make light work of even the heaviest loads.
- Steam + Sani-Save time with a high-temperature cycle that steams and sanitizes. Get a complete wash with no pre-rinsing or soaking necessary and reduce 99.999% of bacteria.
- High Wash Performance-Get a complete wash with no pre-rinse thanks to a variety of wash cycles that provides a powerful clean. No matter how many dishes you load or how dirty they are, rest assured you'll get spotless results every time.

Warranty Information:

- Labor Warranty: Limited 1-year entire appliance
- Warranty Notes: See written warranty for full details
- Parts Warranty: Limited 1-year entire appliance



Model#: CWL112P3RD5

Café™ Built-In Microwave Drawer Oven

Approx Dimensions (HxWxD):

15 15/16 H x 23 7/8 W x 23 5/16 D

- Sensor Cook & Sensor Reheat-Microwave sensor cooking automatically adjusts the time and power for delicious results with packaged foods, leftovers and more.
- Glass Touch Controls-Sleek touch controls make the microwave easy to use and clean.
- Drawer Door-This easy open microwave extends like a cabinet drawer and sits under the counter for added convenience and easy access.
- Electronic Open-Simply push a button to open the handleless microwave door.
- 1.2 cu. ft. Capacity-This 1.2 cu. ft. microwave has plenty of capacity for your favorite dishes.
- Convenient Controls-Quickly microwave your favorites with ease using intuitive cooking controls.

Warranty Information:

- Labor Warranty: Limited 1-year entire appliance
- Parts Warranty: Limited 1-year entire appliance
- Parts Warranty: Limited 5-year magnetron tube
- Warranty Notes: See written warranty for full details





Model#: JWV5301FJDS

GE® 30" Wall-Mount Pyramid Chimney Hood

Approx Dimensions (HxWxD): 9 7/8 H x 30 W x 18 1/2 D

- Easy do-it-yourself Installation
- 350-CFM venting system with boost-Effectively remove smoke, grease, odor and moisture
- Electronic backlit controls-Add a sophisticated look with this up-front, easy-to-use display
- Dual halogen cooktop lighting-Enjoy better visibility with a brightly lit cooktop and surrounding surface
- Night light-Keep a dim light on for visibility at all hours
- Convertible venting options-Select recirculating or external venting
- Optional remote control (JXRC70)-Control your ventilation lighting and fan speed from anywhere in the kitchen



Model#: UXDC53FJDS

10 (ft.) Ceiling Duct Cover Kit

Approx Dimensions (HxWxD):



Model#: GFW655SPVDS

GE® ENERGY STAR® 5.0 cu. ft. Capacity Smart Front Load Steam Washer with SmartDispense™ UltraFresh Vent System with OdorBlock™ and Sanitize + Allergen

Approx Dimensions (HxWxD):

39 3/4 H x 28 W x 32 D

- UltraFresh Vent System With OdorBlock™-The first and only UltraFresh Vent System with OdorBlock™ eliminates excess moisture to help prevent odors ensuring your washer stays fresh and clean
- Microban® antimicrobial technology-Built into components including the gasket, dispenser and draining system delivering protection that lives on load after load
- SmartDispense™ Technology-Save time and make laundry effortless with an intelligent dispenser that holds up to 32 loads of detergent and automatically dispenses the right amount each time
- Sanitize + Allergen-Industry-first cycle sanitizes fabrics to kill 99% of common bacteria and allergens such as dust mites
- Built-in WiFi-Start, stop and monitor your laundry from anywhere while receiving real-time notifications and updates
- Dynamic Balancing Technology (dB™)-Our patented, time saving technology senses and rebalances uneven loads during the spin cycle, providing a quiet wash
- Reversible Door-Easily reverse your washer and dryer door for superior installation flexibility

Warranty Information:

- Parts Warranty: Limited 1-year entire appliance
- Parts Warranty: Limited 10-year motor
- Warranty Notes: See written warranty for full details
- Labor Warranty: Limited 1-year entire appliance



GE APPLIANCES
a Haier company

CustomerNet



Model#: GFD65ESPVDS

GE® ENERGY STAR® 7.8 cu. ft. Capacity Smart Front Load Electric Dryer with Steam and Sanitize Cycle

Approx Dimensions (HxWxD):

39 3/4 H x 28 W x 32 D

- Powersteam-Refresh small loads and dewrinkle larger loads with the power of steam
- WiFi powered by SmartHQ™-Start, stop and monitor your laundry from anywhere while receiving real-time notifications and updates
- Quick Dry-Quickly dries items and small loads for families on the go
- Sanitize Cycle-Sterilize clothing with elevated temperatures designed to kill common household bacteria
- Reduce Static-Prevent static cling with a gentle mist near the end of the cycle
- Wrinkle Care-Prevents wrinkles by extending the tumble without heat
- Damp Alert-Signals when delicate clothes reach the ideal dampness level for ironing or final air drying

Warranty Information:

- Parts Warranty: Limited 1-year entire appliance
- Warranty Notes: See written warranty for full details
- Labor Warranty: Limited 1-year entire appliance





Model#: GFP1528PTDS

GE® Pedestal

Approx Dimensions (HxWxD):

16 H x 28 W x 28 7/8 D

- 16" pedestal-Raises the dryer and washer to a comfortable working level
- Storage drawer-Provides storage for laundry additives or accessories
- Stainless steel ball bearings-Allows easy gliding for drawer operation
- Easy installation-All installation parts are included with pedestal
- Sold separately

Warranty Information:



GFE26JBM/JEM/JMM/JSM/JGM/JYM

GE® ENERGY STAR® 25.6 Cu. Ft. French-Door Refrigerator

DIMENSIONS AND INSTALLATION INFORMATION (IN INCHES)

OVERALL DIMENSIONS	Height to top of door - crown or flat (in.) A	69-7/8
	Height to top of hinge (in.) B	69-3/4
	Height to top of case (in.) C	68-5/8
	Case depth without door (in.) D	29
	Case depth less door handle (in.) E	33-3/8
	Case depth with door handle (in.) F	35-7/8
	Depth with fresh food door open 90° (in.) G	48-3/8
	Width (in.) H	35-3/4
	Width with door open 90° inc. door handle (in.) I	43-3/4
AIR CLEARANCES	Each side (in.)	1/8
	Top (in.)	1
	Back (in.)	2

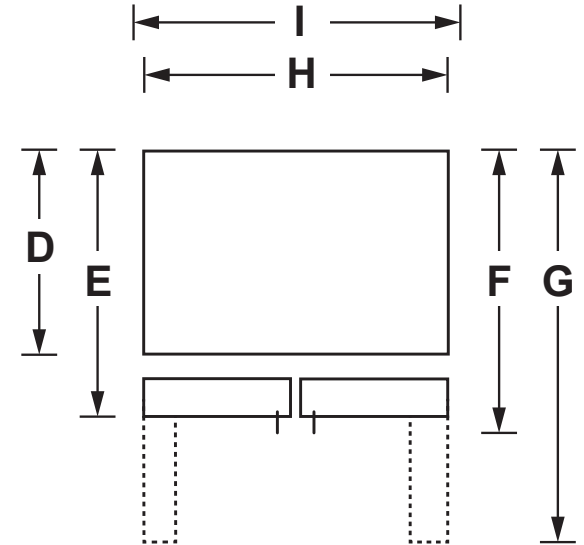
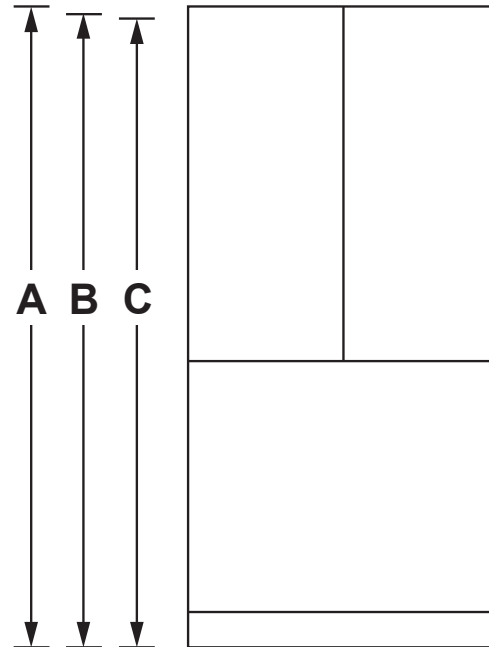

For answers to your Monogram, GE Café™ Series, GE Profile™ Series or GE Appliances product questions, visit our website at geappliances.com or call GE Answer Center® Service, 800.626.2000.



Listed by
Underwriters
Laboratories



As an ENERGY STAR® partner, GE has determined that this product meets the ENERGY STAR guidelines for energy efficiency.

GFE26JBM/JEM/JMM/JSM/JGM/JYM

GE® ENERGY STAR® 25.6 Cu. Ft. French-Door Refrigerator

FEATURES AND BENEFITS

25.6 cu. ft. capacity – Easily store large or bulk food items with three full-width shelves and large capacity

In-the-door icemaker – Frees up valuable space in the fresh-food section for more storage of your favorite foods

Color-matched external Ice and water dispenser – Fills tall bottles, stores and makes ice in the door, saving space

LED lighting – Find exactly what you've been looking for under crisp, clear lighting

Spill-proof shelves – Raised edges help contain spills and make clean up quick and easy

Full-width deli drawer – Allows party trays and larger items to fit easily and remain at the ideal temperature

Quick Space shelf – Quickly slides out of the way to make room for tall items

Advanced water filtration uses XWF replacement filter – Reduces trace pharmaceuticals from water and ice* (* Removes 98% of ibuprofen, atenolol, fluoxetine, progesterone and trimethoprim. These pharmaceuticals are not necessarily in all users' water)

Model GFE26JBMTS – Black stainless

Model GFE26JEMDS – Black slate

Model GFE26JMMES – Slate

Model GFE26JSMSS – Stainless steel

Model GFE26JGMBB – Black

Model GFE26JGMWW – White

Model GFE26JYMFS – Fingerprint resistant stainless

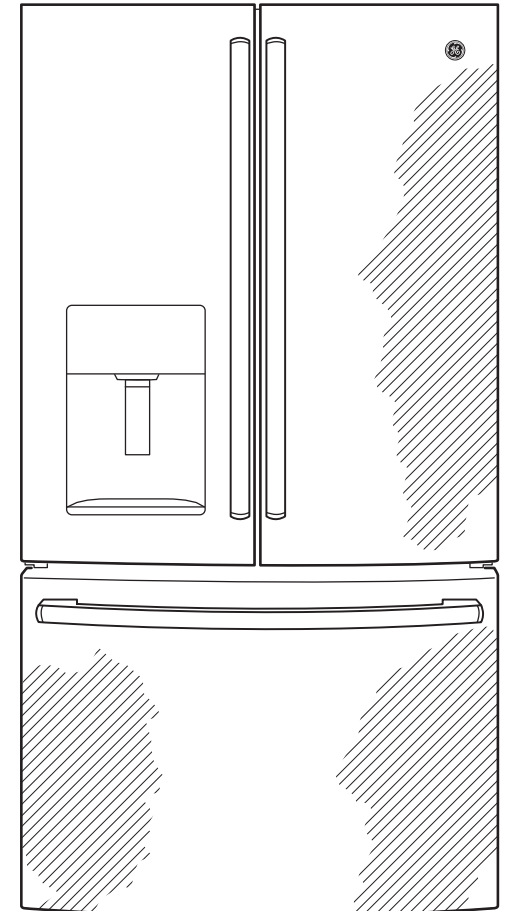

As an ENERGY STAR® partner, GE has determined that this product meets the ENERGY STAR guidelines for energy efficiency.

GG600AV

GE® 30" Slide-In Gas Convection Range with No Preheat Air Fry and EasyWash™ Oven Tray

Dimensions and Installation Information (in inches)

Provide adequate clearances between the range and adjacent combustible surfaces. These dimensions must be met for safe use of your range.

Allow 30" (76.2 cm) minimum clearance between burners and bottom of unprotected wood or metal cabinet, or allow a 24" (61 cm) minimum when bottom of wood or metal cabinet is protected by no less than 1/4" (6.4 mm) thick flame-retardant millboard covered with no less than No. 28 MSG sheet metal (.015" [.38 mm] thick), .015" (.38 mm) thick stainless steel, .025" (0.64 mm) aluminum or .020" (0.5 mm) copper.

Installation of a listed microwave oven or cooking appliance over the cooktop shall conform to the installation instructions packed with that appliance.

For island installation, maintain 2-1/2" minimum from cutout to back edge of countertop and 3" minimum from cutout to side edges of countertop.

Note: Door handle protrudes 3" from door face. Cabinets and drawers on adjacent 45° and 90° walls should be placed to avoid interference with the handle.

Note: Cabinets installed adjacent to slide-in ranges must have an adhesion spec of at least 194° F (90° C) temperature rating.

Before installing, consult installation instructions packed with product for current dimensional data.

For all installations, install the required rear trim to back of range with 4 screws provided.

Electrical Rating: 120V, 60Hz, 13A

Breaker Size: 15A

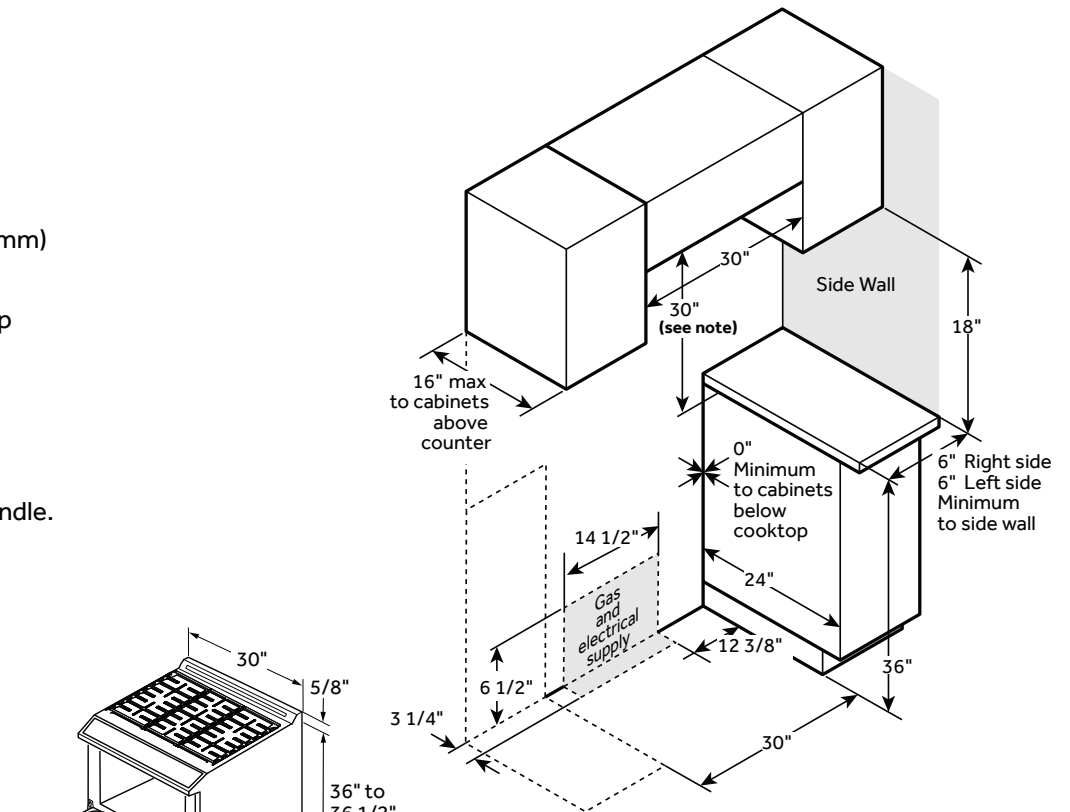

Note: Minimum to bare cabinet above; see Installation Instructions for alternate installation configurations.

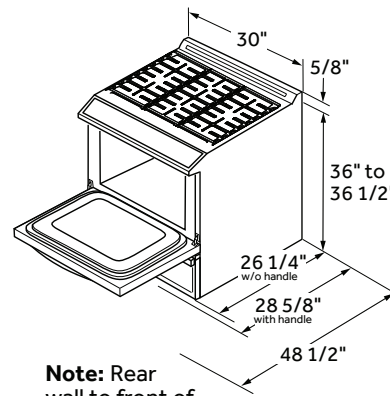

Note: Rear wall to front of door glass.



For answers to your Monogram, Café™, GE Profile™ or GE Appliances product questions, visit our website at geappliances.com or call GE Answer Center® Service, 800.626.2000.



All GE Appliances ranges are equipped with an Anti-Tip device. The installation of this device is an important, required step in the installation of the range.

GG600AV

GE® 30" Slide-In Gas Convection Range with No Preheat Air Fry and EasyWash™ Oven Tray

Features and Benefits

EasyWash™ Oven Tray – Oven cleaning is easier than ever with the EasyWash™ Oven Tray. This enameled tray is easily removed and rinsed clean in the sink or, for bigger messes, guaranteed to fit in all GE Appliances dishwashers.

Built-In WiFi – Built-in WiFi and the SmartHQ™ app give you oven control functions like remote preheat, the ability to monitor and change oven temperature, turn off your oven and more!

No Preheat Air Fry – No preheat air frying is a great way to get crispier versions of your favorite foods in less time.

No Preheat Fresh Reheat – This no preheat mode is USDA MyPlate-Certified and perfect for reheating healthy leftovers from the night before, the to-go box from your favorite restaurant or restoring foods to ideal crispiness, saving you time and delivering delicious results.

No Preheat Pizza – Specifically designed to cook your frozen pizza perfectly, this no preheat option is a time saver and a great way to get dinner on the table fast.

Express Preheat – Get food on the table quicker thanks to a fast preheat oven. In just 7 minutes*, you have a perfectly preheated oven.*Preheats oven in just 7 minutes, bake mode to preheat beep, 350 degrees, one standard rack.

18,000 BTU Power Boil™ Burner – Boil water faster than ever with an 18,000 BTU element that delivers high heat for quick boiling.

Edge-to-Edge Cooktop – A large cooking surface gives you extra room for pots and pans of all sizes and lets cookware move easily from burner to burner.

Convection – Cook and brown foods more evenly with convection cooking that uses a rear fan to circulate hot air.

Precise Simmer Burner – Prepare your delicate dishes over the low, even heat of this precise simmer burner.

Extra-Large Integrated Griddle – With an integrated griddle that is 20% larger than leading competition, you can cook up to six grilled cheeses at once.

Steam Clean – Save your time and effort by steam-cleaning the oven after use without the need for special water, kits or extra steps thanks to this simple steam clean oven function.

Center Oval Burner – Custom cookware and griddles easily fit on this powerful fifth central oval burner that offers a flexible cooking solution.

Heavy-Duty, Dishwasher-Safe Grates – Enjoy a safe and easy-to-clean solution thanks to these heavy-duty, dishwasher-safe grates.

Model GGS600AVWW – White

Model GGS600AVES – Slate

Model GGS600AVFS – Fingerprint-Resistant Stainless

Model GGS600AVDS – Black Slate



Guaranteed Fit

Replace your old 30" free-standing range with a new 30" slide-in model. GE slide-in ranges are guaranteed for an exact fit or GE Appliances will pay up to \$300 toward modifications. Visit geappliances.com for more info.



GDT670SGV/SMV/SYV/SFV

GE® Stainless Steel Interior Dishwasher with Hidden Controls

DIMENSIONS AND INSTALLATION INFORMATION (IN INCHES)

ELECTRICAL RATING

Voltage AC.....120
 Hertz.....60
 Total connected load amperage7.8
 Calrod® heater watts max.....800/500

For use on adequately wired 120-volt, 7.8-amp circuit having 2-wire service with a separate ground wire. This appliance must be grounded for safe operation.

INSTALLATION INFORMATION: Before installing, consult installation instructions packed with product for current dimensional data.

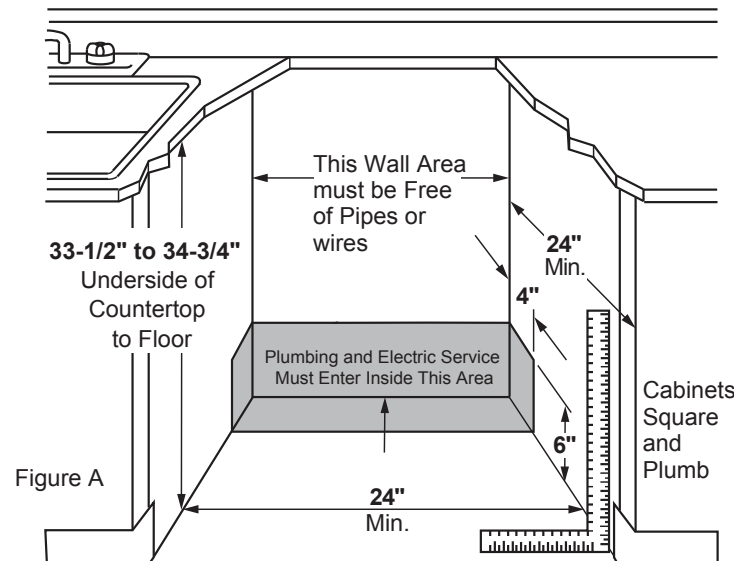
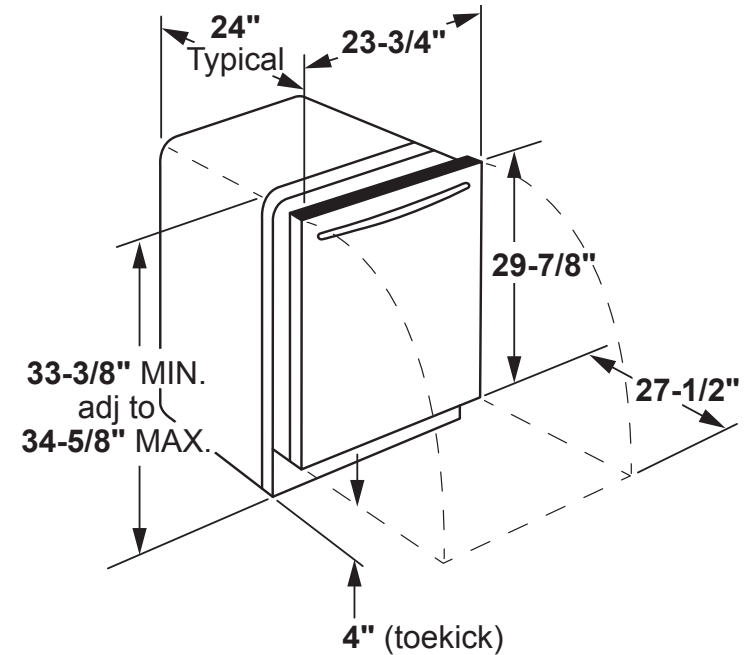

For answers to your Monogram, Café™, GE Profile™ or GE Appliances product questions, visit our website at geappliances.com or call GE Answer Center® Service, 800.626.2000.



Listed by Underwriters Laboratories

GDT670SGV/SMV/SYV/SFV

GE® Stainless Steel Interior Dishwasher with Hidden Controls

FEATURES AND BENEFITS

Dry Boost™ Technology – Dry Boost™ Technology outperforms standard heated-dry dishwashers by getting hard-to-dry items like plastics up to 3 times drier when compared to heated dry.

Third Rack with Removable Silverware Caddy – The versatile Third Rack was redesigned to load more than just silverware with additional space for unique items.

Deep Clean Silverware Jets – A system of deep-cleaning silverware jets blasts the silverware basket from the bottom up, removing all stuck-on food for sparkling results.

4 Bottle Wash Jets – Ensure a deep clean for tall items, narrow glasses, jars and more thanks to this dishwasher with bottle jets. 4 powerful jets direct water and detergent inside to effectively wash hard-to-reach areas.

Smooth-Glide Upper Rack – This dishwasher with a smooth-glide rack makes loading and unloading smooth and simple. It easily extends on stainless steel ball bearings, so you can make light work of even the heaviest loads.

Steam + Sani – Save time with a high-temperature cycle that steams and sanitizes. Get a complete wash with no pre-rinsing or soaking necessary and reduce 99.999% of bacteria.

High Wash Performance – Get a complete wash with no pre-rinse thanks to a variety of wash cycles that provides a powerful clean. No matter how many dishes you load or how dirty they are, rest assured you'll get spotless results every time.

Active Flood Protect – This dishwasher features Active Flood Protect, which prevents potential overflows for greater peace of mind. It works by using a water leak detector to sense when water is too high, pumping it out until a safe level is reached.

Reliable Performance – Enjoy trusted performance from a trusted brand with this American-made, dependable dishwasher that provides totally clean and dry dishes with every cycle.

Piranha™ Hard Food Disposer – The Piranha™ Hard Food Disposer lets you use your dishwasher without pre-rinsing. Its stainless steel impellers rotate to pulverize food particles and an anti-jamming design makes sure wash arms stay unclogged.

45 dBA Dishwasher – Enjoy a peaceful kitchen and a powerful wash with this super-silent 45 dBA dishwasher.

Extra-Large Capacity – This extra-large capacity dishwasher has enough space for 16 place settings and large dish-are, making cleanup easy after large gatherings.

Optional WiFi – Monitor this dishwasher with a smartphone and a WiFi adapter (sold separately) to enjoy a smart dishwasher experience. Simply attach the adapter and start using the SmartHQ™ app to control and monitor your unit remotely. You can even reorder detergent.

1-Hour Wash Cycle – Unload spotless plates, glasses, pots and pans without waiting hours for the dishwasher to finish with this one-hour dishwasher cycle.

AutoSense Cycle – This energy-saving dishwasher has an AutoSense Cycle that detects soil level and amount of dishes before automatically adjusting the wash setting for the ultimate clean.

Wash Zones – Wash a true half-load in the upper or lower rack whenever you need to thanks to this dishwasher with wash zones. The feature works in combination with most cycles, saving you time and conserving energy.

Flush Installation – Cabinet-depth flush installation ensures your dishwasher blends in with the design of your kitchen without sacrificing space for dishes inside.

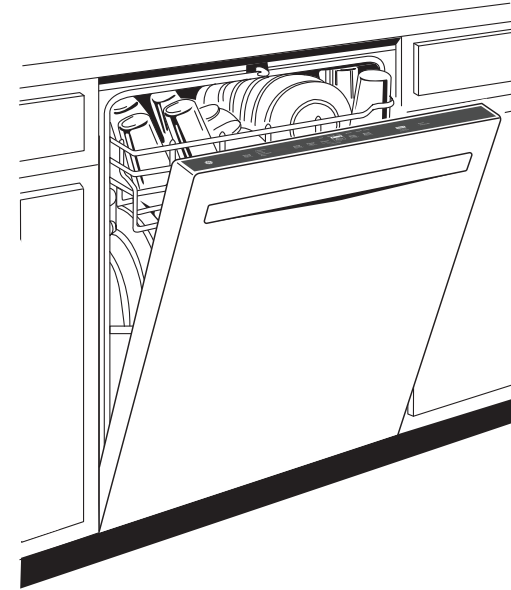

Model GDT670SGVBB – Black

Model GDT670SGVWW – White

Model GDT670SMVES – Slate

Model GDT670SFVDS – Black Slate

Model GDT670SYVFS – Fingerprint Resistant Stainless



Café™ Built-In Microwave Drawer Oven

CWL112P4RW5 / CWL112P2RS1 / CWL112P3RD5

CAFÉ

DISTINCT BY DESIGN™



ALSO
AVAILABLE IN



CWL112P2RS1
Stainless Steel



CWL112P3RD5
Matte Black

FEATURES & BENEFITS

Sensor Cook & Sensor Reheat – Microwave sensor cooking automatically adjusts the time and power for delicious results with packaged foods, leftovers and more.

Glass Touch Controls – Sleek touch controls make this smart microwave easy to use and clean.

Drawer Door – This easy open microwave extends like a cabinet drawer and sits lower than a typical countertop unit for added convenience and easy access.

Electronic Open – Simply push a button to open the handleless microwave door.

1.2 cu. ft. – This mid-sized microwave has plenty of capacity thanks to the innovative drawer design.

Convenient Controls – Quickly microwave your favorites with ease using intuitive cooking controls.

FEATURES

Control Type	Glass Touch
Electronic Digital Display with Clock	Yes
Style	Built-In
Interior Oven Light	Incandescent
Power Levels	10
Microwave Sensor Cooking Controls	Popcorn Potato Chicken Fish Meat Vegetable - Fresh Vegetable - Frozen Vegetable - Canned
Control Features	Add 30 Sec Mute On/Off Start/Pause Clear/Off Lock controls Power Level Timer Set Clock Express Cook Weight/Time Defrost Cook Time Open Close Melt Soften Beverage Popcorn Sensor Reheat Sensor Cook
Microwave Oven Interior	Coated
Microwave Watts (IEC-705)	1,000W

CAPACITY

Total Capacity (cubic feet)	1.2 cu ft
-----------------------------	-----------

TECHNICAL DETAILS

Electrical Input - 120V Watts	1500
Input Volts/Hertz	120/60

WEIGHTS & DIMENSIONS

Approximate Shipping Weight	80 lb
Cabinet Width	24 in
Cavity (W x H x D)	17-1/4 x 7-1/8 x 17-1/2
Net Weight	69 lb
Overall Depth	23-5/16 in
Overall Height (Rear)	14-19/32 in
Overall Height (Front)	15-15/16 in
Overall Width	23-7/8 in

WARRANTY

Parts warranty	Limited 1-year entire appliance Limited 5-year magnetron tube
Labor warranty	Limited 1-year entire appliance
Warranty notes	See written warranty for full details

Café™ Built-In Microwave Drawer Oven

CWL112P4RW5 / CWL112P2RS1 / CWL112P3RD5

CAFÉ

DISTINCT BY DESIGN™

DIMENSIONS AND INSTALLATION INFORMATION (IN INCHES)

OVERALL DIMENSIONS

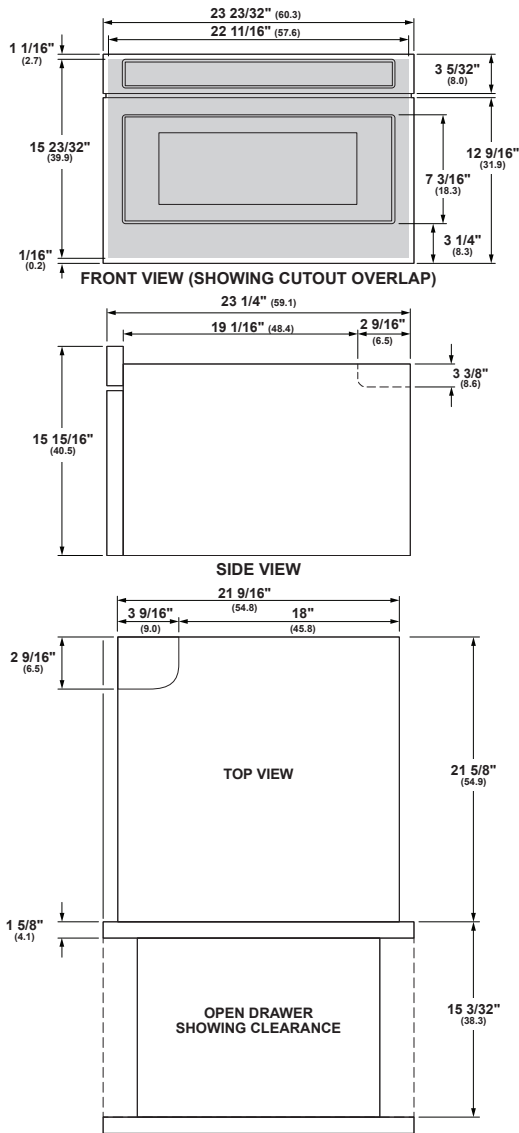

STANDARD INSTALLATION

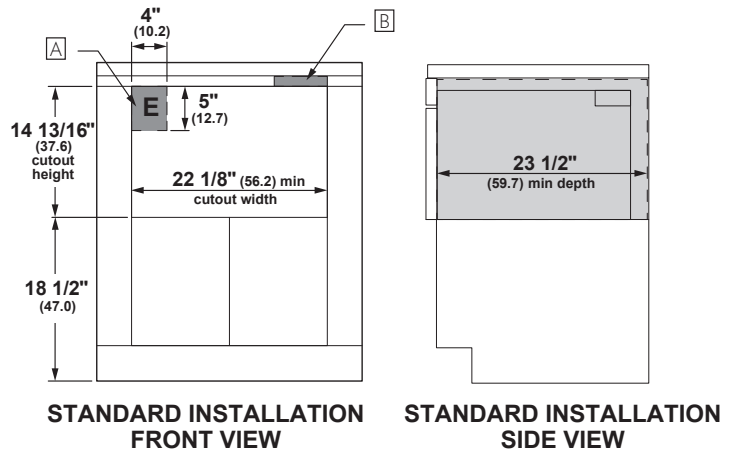

FLUSH INSTALLATION

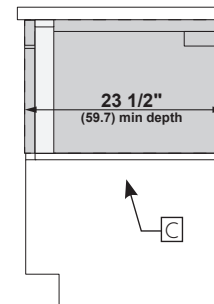
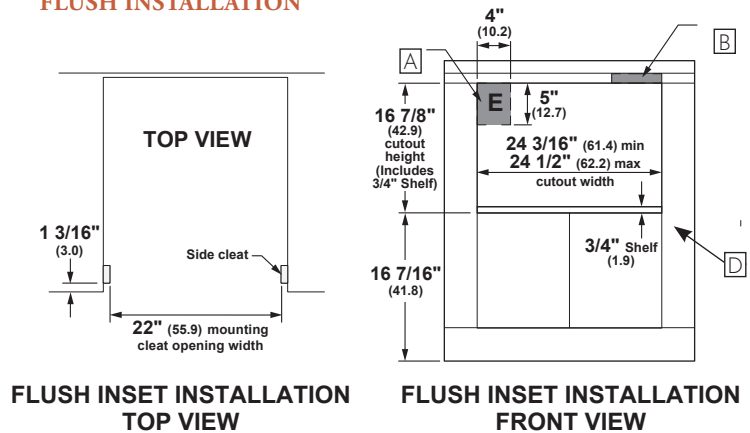

- A** Junction box location (May also be located in adjacent cabinet.)
- B** To reduce the risk of tipping of the drawer, the Anti-Tip block must be properly installed located 14-13/16" above the floor on which the Microwave Drawer will sit. The Anti-Tip block must be provided and pre-installed by the purchaser or builder before install can be done. The Anti-Tip block prevents serious injury that might result from spilled hot liquids.
- C** Cleats may be visible and should be finished to match cabinetry.
- D** The face of the shelf must sit 1-7/8" back from the face of the cabinet. See installation instructions for further details including the installation of 24" flush mount deflector vent.

Dimensions in parentheses are in centimeters unless otherwise noted. Actual product dimensions may vary due to manufacturing tolerances.

JVW5301SJ/EJ/BJ/FJ

GE® 30" Wall-Mount Pyramid Chimney Hood

DIMENSIONS AND INSTALLATION INFORMATION (IN INCHES)

INSTALLATION INFORMATION:

Before installing, consult Use & Care/installation instructions packed with product for current dimensional data.

OPTIONAL ACCESSORIES

UXDC72SJSS/FJDS/BJTS – 9(ft.) Ceiling Duct Cover Kit

UXDC53SJSS/EJES/BJTS/FJDS – 10(ft.) Ceiling Duct Cover Kit

For 30" distance from counter to hood:

Below 8'-4" ceiling height – no duct cover required

8'-4" – 9'-6" ceiling height – use UXDC72SJSS/FJDS/BJTS

Above 9'-7" ceiling height – use UXDC53SJSS/EJES/BJTS/FJDS

Refer to Installation Instructions for exact specifications

UXRC70 – Remote Control

JXCF72 – Charcoal Filter (needed if used in recirculation mode)

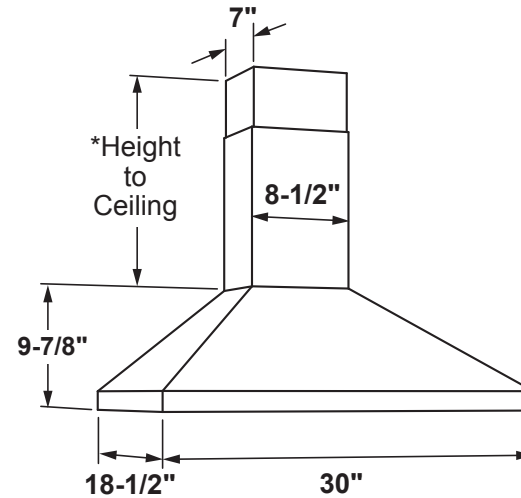

30" Models Require a 30"-Wide Opening

*The supplied duct cover fits 7'-4" to 9'-0" ceiling heights (10' with optional high ceiling kit UXDC53)

AMP RATING	
120V	2.5

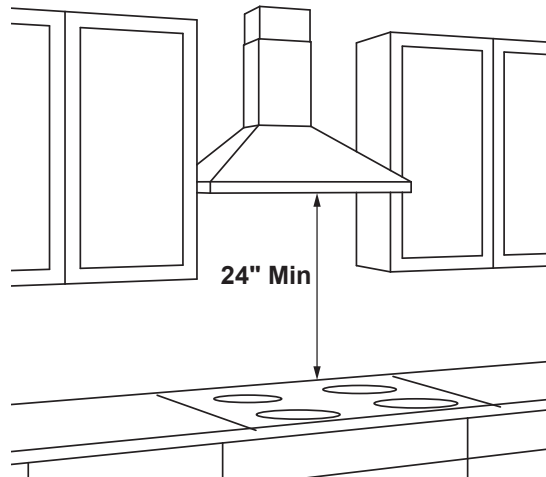

The vent hood must be installed 24" min. above the cooking surface. For optimal performance, installing the hood more than 38" above the cooking surface is not recommended. The hood installation height above the cooking surface depends upon ceiling height. The telescopic duct cover conceals the ductwork running from the top of the hood to the ceiling.

NOTE: Installation height should be measured from the cooking surface to the lowest part of the hood. This hood may be installed onto a wall and vented to the outdoors, or it can be installed for recirculating operation. Parts for recirculating operation are supplied with the hood. However, when installed for recirculating operation, the optional charcoal Filter JXCF72 will need to be purchased separately.



For answers to your GE Profile™ Series or GE Appliances product questions, visit our website at geappliances.com or call GE Answer Center® Service, 800.626.2000.



Specification Revised 01/20

JVW5301SJ/EJ/BJ/FJ

GE® 30" Wall-Mount Pyramid Chimney Hood

FEATURES AND BENEFITS

350-CFM venting system with boost – Effectively remove smoke, grease, odor and moisture

Electronic backlit controls – Add a sophisticated look with this up-front, easy-to-use display

Dual halogen cooktop light – Enjoy better visibility with a brightly lit cooktop and surrounding surface

Night light – Keep a dim light on for visibility at all hours

Convertible venting options – Select recirculating or external venting

Remote control option – Control your ventilation lighting and fan speed from anywhere in the kitchen

Model JVW5301SJSS – Stainless steel

Model JVW5301EJES – Slate

Model JVW5301BJTS – Black stainless

Model JVW5301FJDS – Black slate

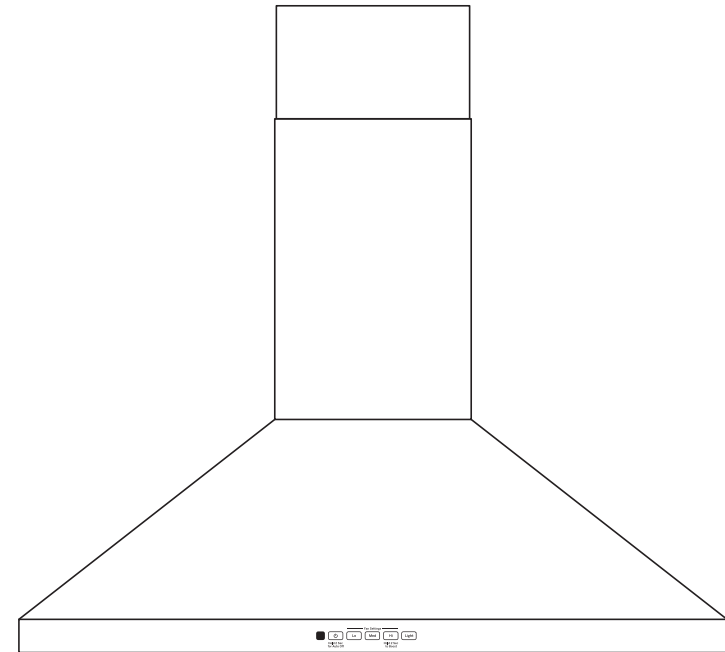

GE® 5.0 cu. ft. Capacity Front Load ENERGY STAR® Steam Washer with SmartDispense™ and UltraFresh Vent System with OdorBlock™

GE® 5.0 cu. ft. Capacity Front Load

ENERGY STAR® Steam Washer with SmartDispense™ and UltraFresh Vent System with OdorBlock™

DIMENSIONS AND INSTALLATION INFORMATION (IN INCHES)

ELECTRIC RATING

120V	11.0A, 60Hz
------	-------------

INSTALLATION INFORMATION:

For complete information, see installation instructions packed with your washer.

INCLUDED:

- Power cord - up to 66" length
- Drain hose - up to 60" length

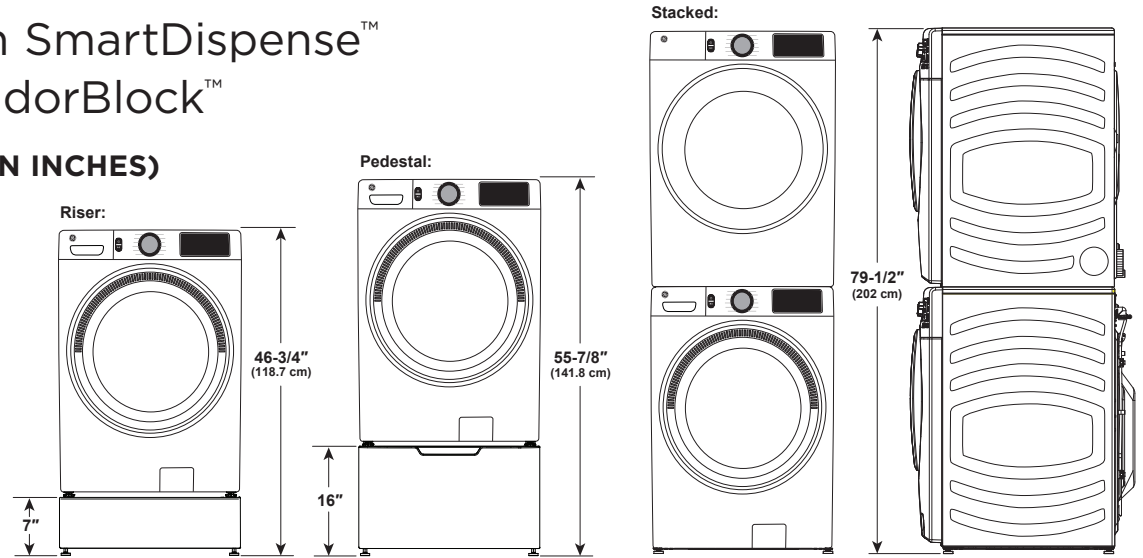

ADA Compliant

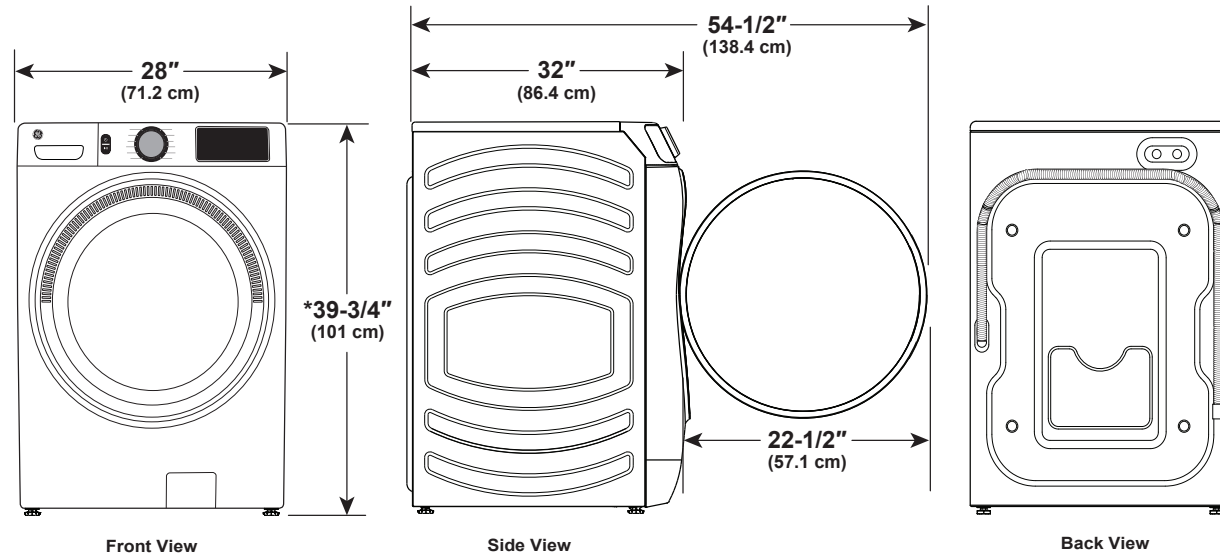

*With leveling legs retracted:
39-3/4" (101 cm).
With leveling legs fully extended:
40-5/8" (103.1 cm).



For answers to your Monogram, GE Café™, GE Profile™ or GE Appliances product questions, visit our website at geappliances.com or call GE Answer Center® Service, 800.626.2000.



GE® 5.0 cu. ft. Capacity Front Load ENERGY STAR® Steam Washer with SmartDispense™ and UltraFresh Vent System with OdorBlock™

GFW655SSVWW / GFW655SPVDS

SPECIAL INSTALLATION REQUIREMENTS:

STACKED INSTALLATION:

-Brackets for stacking dryer over washer are not included with the washer. Order part no. GFA28KITN.

ALCOVE OR CLOSET INSTALLATION:

-If your dryer is approved for installation in an alcove or closet, it will be stated on a label on the dryer back.

-The dryer MUST be exhausted to the outside.

-Minimum clearances between dryer cabinet and adjacent walls or other surfaces are: 0" all sides and top.*

-Closet doors must be louvered or otherwise ventilated and must contain a minimum of 60 sq. in. of open area equally distributed. If this closet contains both a washer and a dryer, doors must contain a minimum of 120 sq. in. of open area equally distributed.

-No other fuel-burning appliance shall be installed in the same closet with a gas dryer.

BATHROOM OR BEDROOM INSTALLATION:

-The dryer MUST be exhausted to the outdoors.

-The installation must conform with the local codes, or in the absence of local codes, with the National Electric Code and National Fuel Gas Code, ANSI Z223.

MINIMUM CLEARANCE OTHER THAN ALCOVE OR CLOSET INSTALLATIONS:

-Minimum clearances to combustible surfaces 0" all sides and top.*

FOR MORE INFORMATION ON VENTING KITS AND ACCESSORIES, PLEASE CALL 1-800-GE-CARES.

*For improved performance, a 1/2" clearance is suggested on each side.

**Accessories sold separately.



For answers to your Monogram, GE Café™, GE Profile™ or GE Appliances product questions, visit our website at geappliances.com or call GE Answer Center® Service, 800.626.2000.

WEIGHT

-Carton weight 255.7 lbs.

-Product weight 246 lbs.

ACCESSORIES**

GE Part Number	Description
WR97X27706	Touch-up Paint (Carbon Graphite) .06 oz.
WB64X5025	Touch-up Paint (White) .06 oz.
WH49X316	Drain Hose Extension
PM7X2	Universal Low-Profile Floors Tray (White)
WX17X10001CA	Vibration Pads
WH41X10207	Fill Hose
GFP1528SNWW	Pedestal Accessory (White)
GFP1528PTDS	Pedestal Accessory (Carbon Graphite)
GFR0728SNWW	Riser (White)
GFR0728PTDS	Riser (Carbon Graphite)
GFA28KITN	Stacking Kit

WARRANTY

Labor Warranty	Limited 1-year entire appliance
Parts Warranty	Limited 1-year entire appliance Limited 10-year motor



Listed by Underwriters Laboratories

GE® 5.0 cu. ft. Capacity Front Load ENERGY STAR® Steam Washer with SmartDispense™ and UltraFresh Vent System with OdorBlock™

GE® 5.0 cu. ft. Capacity Front Load ENERGY STAR® Steam Washer with SmartDispense™ and UltraFresh Vent System with OdorBlock™

FEATURES AND BENEFITS

UltraFresh Vent System with OdorBlock™ – The first and only UltraFresh Vent System with OdorBlock™ eliminates excess moisture to help prevent odors ensuring your washer stays fresh and clean.

Microban® Antimicrobial Technology – Built into components including the gasket, dispenser and draining system delivers protection that lives on load after load.

SmartDispense™ Technology – Save time and make laundry effortless with an intelligent dispenser that holds up to 32 loads of detergent and automatically dispenses the right amount each time.

Built-in WiFi – Start, stop and monitor your laundry from anywhere while receiving real-time notifications and updates.

Dynamic Balancing Technology (dB™) – Our patented, time saving technology senses and re-balances uneven loads during the spin cycle, providing a quiet wash.

Reversible Door – Easily reverse your washer and dryer door for superior installation flexibility.

Quick Wash Cycle – Provides a fast 20 minute wash for lightly soiled items.

Sanitize + Allergen – Industry-first cycle sanitizes fabrics to kill 99% of common bacteria and allergens such as dust mites.

Steam Cycles – Safely penetrates deep into fabric fibers, loosening stains to deliver enhanced cleaning performance.

Dryer Control™ – When units are stacked, turn on and control your dryer settings right from your washer's control panel, eliminating the need to reach the dryer's control panel.

More Water Option – For bulky items like a king-sized comforter or for heavily soiled loads, this option adds up to an additional 3 gallons of water for a deep water wash and rinse.

Shallow Depth – Never compromise on convenience with this 32" shallow depth washer that easily fits into tight spaces like an alcove or closet, making it a suitable solution for homes of any size.

Time Saver – When you need to get a full load of clothes clean in only 37 minutes.

My Settings – Store preferred dry cycle settings for later use, maximize time and alleviate adjusting cycle preferences with every load.

Model GFW655SSVWW – White

Model GFW655SPVDS – Carbon Graphite



For answers to your Monogram, GE Café™, GE Profile™ or GE Appliances product questions, visit our website at geappliances.com or call GE Answer Center® Service, 800.626.2000.



Listed by
Underwriters
Laboratories

GFD65ESSVWW / GFD65ESPVDS

GE® 7.8 cu. ft. Capacity Front Load Electric Dryer with Steam

DIMENSIONS AND INSTALLATION INFORMATION (IN INCHES)

ELECTRIC DRYER RATING	
120V/240V	5600W, 25A, 60Hz
120V/208V	4300W, 23A, 60Hz

EXHAUST OPTIONS: 4-way via rear, left, right, and bottom. (The right, left, and bottom venting options require Side Vent Kit: GFA28DSVN)

CIRCUIT REQUIREMENTS: An individual, properly grounded branch circuit, protected by a 30-amp circuit breaker or a time-delay fuse, is required.

NOTE: Dryer wall outlet must be located within 36" of service cord entry and accessible when dryer is mounted in position.

INSTALLATION INFORMATION: For complete information, see installation instructions packed with your dryer.

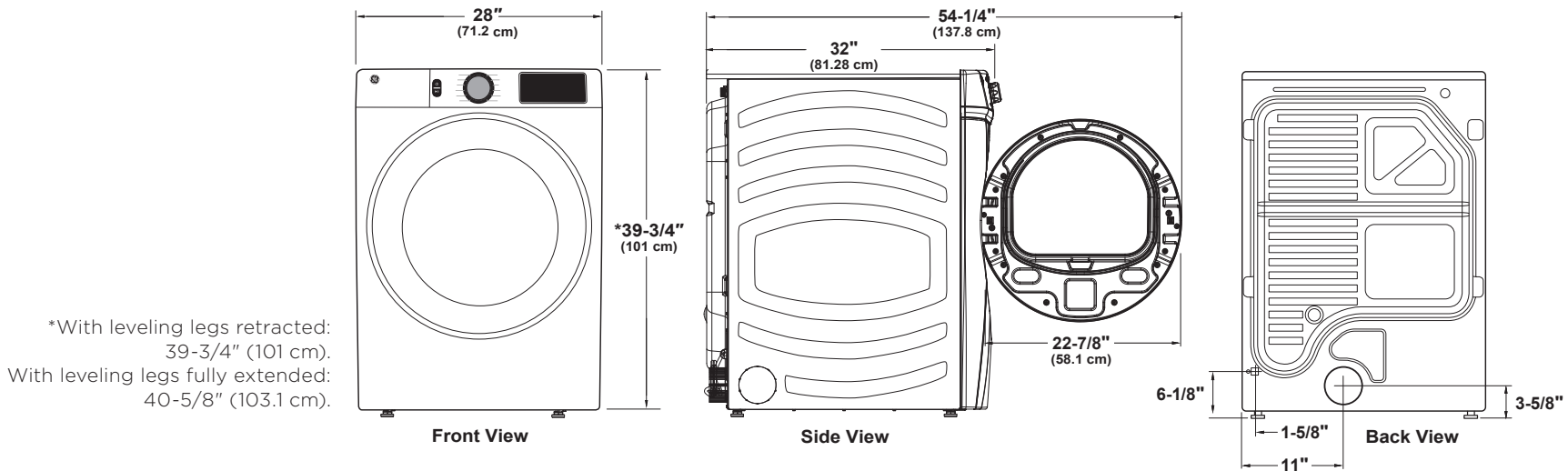
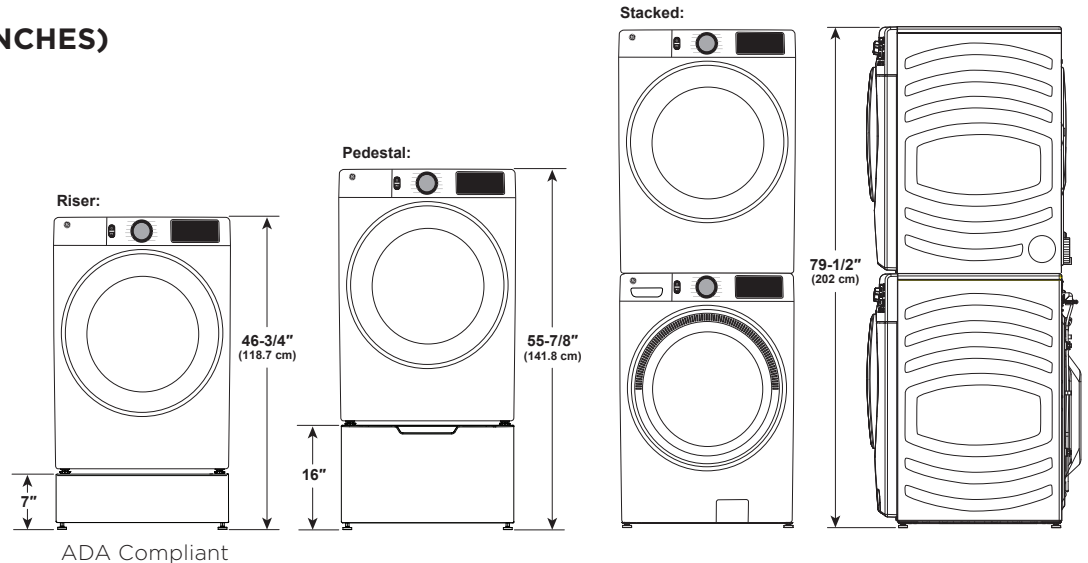

For answers to your Monogram, Café™, GE Profile™ or GE Appliances product questions, visit our website at geappliances.com or call GE Answer Center® Service, 800.626.2000.



GFD65ESSVWW / GFD65ESPVDS

GE® 7.8 cu. ft. Capacity Front Load Electric Dryer with Steam

SPECIAL INSTALLATION REQUIREMENTS:

STACKED INSTALLATION:

Brackets for stacking dryer over washer are not included with the dryer. Order part no. GFA28KITN.

ALCOVE OR CLOSET INSTALLATION:

If your dryer is approved for installation in an alcove or closet, it will be label on the dryer back.

The dryer MUST be exhausted to the outside.

Minimum clearances between dryer cabinet and adjacent walls or other surfaces are: 0" all sides and top.*

Closet doors must be louvered or otherwise ventilated and must contain a minimum of 60 sq. in. of open area equally distributed. If this closet contains both a washer and a dryer, doors must contain a minimum of 120 sq. in. of open area equally distributed.

No other fuel-burning appliance shall be installed in the same closet with a gas dryer.

BATHROOM OR BEDROOM INSTALLATION:

The dryer MUST be exhausted to the outdoors.

The installation must conform with the local codes, or in the absence of local codes, with the National Electric Code and National Fuel Gas Code, ANSI Z223 for gas dryers.

MINIMUM CLEARANCE OTHER THAN ALCOVE OR CLOSET INSTALLATIONS:

Minimum clearances to combustible surfaces 0" all sides and top.*

FOR MORE INFORMATION ON VENTING KITS AND ACCESSORIES, PLEASE CALL 1-800-GE-CARES.

*For improved performance, a 1/2" clearance is suggested on each side.

**Accessories sold separately.

WEIGHT

-Carton weight 142 lbs.

-Product weight 132 lbs.

DRYER ACCESSORIES**

GE Part Number	Description
WB64X5025	Touch-up Paint (White) .06 oz.
WR97X27706	Touch-Up Paint (Carbon Graphite) - 0.6 oz
WE02X29449	Dryer Rack Assembly
GFA28DSVN	Side Vent Kit
WH41X10207	Inlet Hose
WX17X10001CA	Vibration Pads
GFP1528SNWW	Pedestal Assembly (White)
GFP1528PTDS	Pedestal Assembly (Carbon Graphite)
GFR0728SNWW	Riser (White)
GFR0728PTDS	Riser (Carbon Graphite)
GFA28KITN	Stacking Kit

WARRANTY

Labor Warranty	Limited 1-year entire appliance
Parts Warranty	Limited 1-year entire appliance Limited 10-year motor



For answers to your Monogram, Café™, GE Profile™ or GE Appliances product questions, visit our website at geappliances.com or call GE Answer Center® Service, 800.626.2000.



Specification Revised 6/23

GFD65ESSVWW / GFD65ESPVDS

GE® 7.8 cu. ft. Capacity Front Load Electric Dryer with Steam

DRYER EXHAUSTING INFORMATION -METAL DUCT ONLY

For complete information, see installation instructions packed with your dryer.

DUCTING MATERIALS: For best performance, this dryer should be vented with 4" diameter all rigid metal exhaust duct. If rigid metal duct cannot be used, then UL-listed flexible metal (semi-rigid) ducting can be used (Kit WX08X10077). In special installations, it may be necessary to connect the dryer to the house vent using a flexible metal (foil-type) duct. A UL-listed flexible metal (foil-type) duct may be used **ONLY** in installations where rigid metal or flexible metal (semi-rigid) ducting cannot be used **AND** where a 4" diameter can be maintained throughout the entire length of the transition duct. Please see installation instruction packed with your dryer for complete instructions when using flexible metal (foil type) ducting.

EXHAUST LENGTH CALCULATION:

1. Determine the number of 90° turns needed for your installation. If you exhaust to the side or bottom of dryer, add one turn.
2. The maximum length of 4" rigid (aluminum or galvanized) duct which can be tolerated is shown in the table.

A turn of 45° or less may be ignored. Two 45° turns within the duct length should be treated as a 90° elbow.

A turn over 45° should be treated as a 90° elbow.

Dryers must be exhausted to the outside.

CAUTION: For personal safety do not terminate exhaust into a chimney, under any enclosed house floor (crawl space), or into an attic, since the accumulated lint could create a fire hazard or moisture could cause damage. Never terminate the exhaust into a common duct or plenum with a kitchen exhaust, since the combination of lint and grease could create a fire hazard.

Exhaust ducts should be terminated in a dampered wall cap to prevent back drafts, bird nesting, etc. The wall cap must also be located at least 12" above the ground or any other obstruction with the opening pointed down.

FOR MORE INFORMATION ON VENTING KITS AND ACCESSORIES, PLEASE CALL 1-800-GE-CARES.

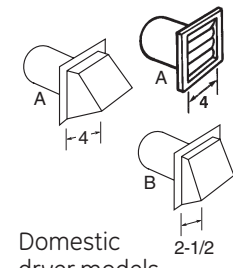

		Best performance	
		Maximum length of 4" dia. rigid metal duct	
		Exhaust hood type	
Domestic dryer models	Number of 90° turns	A 4" opening	B 2-1/2" opening
		0	90 ft.
1	60 ft.	45 ft.	
2	45 ft.	35 ft.	
3	35 ft.	25 ft.	
4	25 ft.	15 ft.	

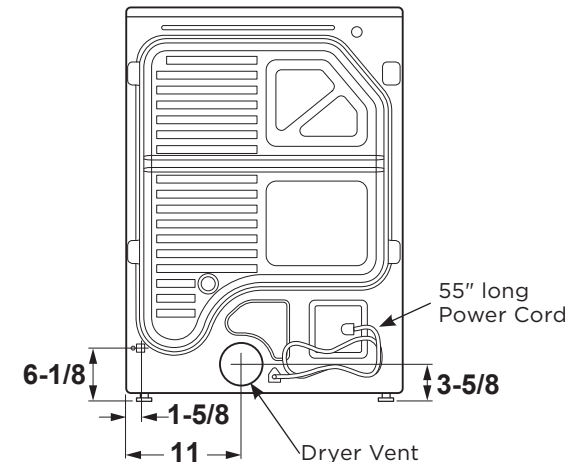

For answers to your Monogram, Café™, GE Profile™ or GE Appliances product questions, visit our website at geappliances.com or call GE Answer Center® Service, 800.626.2000.



Specification Revised 6/23

GFD65ESSVWW / GFD65ESPVDS

GE® 7.8 cu. ft. Capacity Front Load Electric Dryer with Steam

FEATURES AND BENEFITS

Powersteam – Refresh small loads and dewrinkle larger loads with the power of steam.

Built-in WiFi – Start, stop and monitor your laundry from anywhere while receiving real-time notifications and updates.

Quick Dry – Quickly dries items and small loads for families on the go.

Reduce Static – Prevents static cling with a gentle mist near the end of the cycle.

Sanitize Cycle – Sterilize clothing with elevated temperatures designed to kill common household bacteria.

Wrinkle Care – Prevents wrinkles by extending the tumble without heat.

Damp Alert – Signals when delicate clothes reach the ideal dampness level for ironing or final air drying.

Vent Sensor – Provides alerts when a restriction is detected in your dryer vent.

4 Way Venting – Easy-to-change venting options provide the ultimate installation flexibility to fit in your home.

Shallow Depth – Never compromise on convenience with this 32" shallow depth unit that easily fits into tight spaces like an alcove or closet, making it a suitable solution for homes of any size.

Reversible Door – Easily reverse your washer and dryer door for superior installation flexibility.

My Settings – Store preferred dry cycle settings for later use, maximize time and alleviate adjusting cycle preferences with every load.

Model GFD65ESSVWW – White

Model GFD65ESPVDS – Carbon Graphite



4-way Venting Option



For answers to your Monogram, Café™, GE Profile™ or GE Appliances product questions, visit our website at geappliances.com or call GE Answer Center® Service, 800.626.2000.





GE APPLIANCES
a Haier company

WARRANTY INFORMATION

DISCOVER OUR APPLIANCE BRANDS

MONOGRAM

C A F É



Profile™

Haier

Hotpoint.

LIMITED WARRANTY INFORMATION

(SEE WRITTEN WARRANTY FOR COMPLETE DETAILS)



The condensed list below is a convenient overview of the written warranties offered on various Monogram appliances described in this document for products manufactured on or after January 1, 2006. For complete warranty details on a specific Monogram model, visit Monogram.com or contact your nearest Monogram reseller, or call Monogram Factory Service, toll-free, 800-432-2737.

PRO RANGE

FOR THE PERIOD OF	MONOGRAM WILL REPLACE
Limited two-year warranty	For two years from date of original purchase, we will provide, free of charge, parts and service labor in your home to repair or replace any part of the appliance that fails because of a manufacturing defect.
Limited five-year warranty	For five years from the date of original purchase, we will provide, free of charge, replacement gas surface burners if they fail in normal household use. (The grill, griddle and oven burners are not included.) You pay for the service trip to your home and all service labor charges.
Limited lifetime warranty	For the lifetime of the gray porcelain enamel oven racks, we will provide, free of charge, replacement racks if they fail in normal household use. You pay for the service trip to your home and all service labor charges.

RANGETOP & COOKTOPS

FOR THE PERIOD OF	MONOGRAM WILL REPLACE
Limited two-year warranty	For two years from date of original purchase, we will provide, free of charge, parts and service labor in your home to repair or replace any part of the appliance that fails because of a manufacturing defect.
Limited five-year warranty	For five years from the date of original purchase, we will provide, free of charge, replacement gas surface burners if they fail in normal household use. (The grill and griddle are not included.) You pay for the service trip to your home and all service labor charges.

WALL OVENS

FOR THE PERIOD OF	MONOGRAM WILL REPLACE
Limited two-year warranty	For two years from date of original purchase, we will provide, free of charge, parts and service labor in your home to repair or replace any part of the appliance that fails because of a manufacturing defect.

ADVANTIUMS

FOR THE PERIOD OF	MONOGRAM WILL REPLACE
Limited two-year warranty	Any part of the oven which fails due to a defect in materials or workmanship. During this limited two-year warranty, Monogram will also provide, free of charge, all labor and related service costs to replace the defective part.
Limited five-year warranty	The magnetron tube, if the magnetron tube fails due to a defect in materials or workmanship. During this five-year limited warranty, you will be responsible for any labor or in-home service costs.

MICROWAVES

FOR THE PERIOD OF	MONOGRAM WILL REPLACE
Limited two-year warranty	For two years from the date of the original purchase, Monogram will replace any part of the microwave oven which fails due to a defect in materials or workmanship. During this limited two-year warranty, Monogram will also provide, free of charge, all labor and related service to replace the defective part.
Limited third through fifth-year warranty	For the third through fifth years from the date of the original purchase, Monogram will replace the magnetron tube, if the magnetron tube fails due to a defect in materials or workmanship. During this third through fifth-year limited warranty, you will be responsible for any labor or in-home service costs.

HOODS

FOR THE PERIOD OF	MONOGRAM WILL REPLACE
Limited two-year warranty	For two years from date of original purchase, we will provide, free of charge, parts and service labor in your home to repair or replace any part of the unit that fails because of a manufacturing defect.

WARMING DRAWER

FOR THE PERIOD OF	MONOGRAM WILL REPLACE
Limited two-year warranty	Any part of the warming drawer which fails due to a defect in materials or workmanship. During this limited two-year warranty, Monogram will provide, free of charge, all labor and in-home service to replace the defective part.

HEARTH OVEN

FOR THE PERIOD OF	MONOGRAM WILL REPLACE
Limited two-year warranty	For two years from date of original purchase, we will provide, free of charge, parts and service labor in your home to repair or replace any part of the oven that fails because of a manufacturing defect.

REFRIGERATION

FOR THE PERIOD OF	MONOGRAM WILL REPLACE
Limited two-year warranty	For two years from date of original purchase, we will provide, free of charge, parts and service labor in your home to repair or replace any part of the refrigerator or freezer that fails because of a manufacturing defect.
Limited five-year warranty	For five years from date of original purchase, we will provide, free of charge, parts and service labor in your home to repair or replace any part of the sealed refrigerating system (the compressor, condenser, evaporator and all connecting tubing) that fails because of a manufacturing defect.
Limited additional sixth-through twelfth-year warranty on the sealed system	For the sixth through twelfth year from the date of the original purchase, we will provide, free of charge, replacement parts for any part of the sealed refrigerating system (the compressor, condenser, evaporator and all connecting tubing) that fails because of a manufacturing defect. You pay for the service trip to your home and for service labor charges.
Limited thirty-day warranty on water filter cartridge (Water filter, if included)	From the date of the original purchase we will provide, free of charge, replacement parts for any part of the water filter cartridge that fails because of a manufacturing defect. During this limited thirty-day warranty, we will also provide, free of charge, a replacement water filter cartridge.

UNDERCOUNTER

FOR THE PERIOD OF	MONOGRAM WILL REPLACE
Limited two-year warranty	For two years from date of original purchase, we will provide, free of charge, parts and service labor in your home to repair or replace any part of the unit that fails because of a manufacturing defect.
Limited third through fifth-year warranty	For the third through fifth years from date of original purchase, we will provide, free of charge, parts and service labor in your home to repair or replace any part of the sealed refrigerating system (the compressor, condenser, evaporator and all connecting tubing) that fails because of a manufacturing defect.

ICEMAKERS

FOR THE PERIOD OF	MONOGRAM WILL REPLACE
One Year Warranty	Any part of the ice machine which fails due to a defect in materials or workmanship. During the limited one-year warranty, GE Appliances will also provide, free of charge, all labor and related service to replace the defective part.
Five Year Warranty	Any part of the sealed refrigeration system. During the limited five-year sealed refrigerating system warranty, GE Appliances will also provide, free of charge, all labor and related service to replace the defective part in the sealed refrigerating system.

DISHWASHER

FOR THE PERIOD OF	MONOGRAM WILL REPLACE
Limited two-year warranty	Any part of the dishwasher which fails due to a defect in materials or workmanship. During this limited two-year warranty, Monogram will also provide, free of charge, all labor and in-home service to replace the defective part.
Three to Five Year Warranty	The dishwasher rack and/or the electronic control module, if these should fail due to a defect in materials or workmanship. During this three to five year limited warranty, you will be responsible for any labor or in-home service costs.
Limited lifetime warranty	The stainless steel tub or door liner, if it fails to contain water due to a defect in materials or workmanship. During this limited lifetime warranty, Monogram will also provide, free of charge, all labor and in-home service to replace the defective part.

EXCLUSION OF IMPLIED WARRANTIES – Your sole and exclusive remedy is product repair as provided in this Limited Warranty. Any implied warranties, including the implied warranties of merchantability or fitness for a particular purpose, are limited to one year or the shortest period allowed by law.

This warranty is extended to the original purchaser and any succeeding owner for products purchased for home use within the USA. In Alaska, the One-Year Warranty excludes the cost of shipping, or service calls to your home. Some states do not allow the exclusion or limitation of incidental or consequential damages. This warranty gives you specific legal rights, and you may also have other rights which vary from state to state. To know what your legal rights are, consult your local or state consumer affairs office or your state's Attorney General.

Limited Warranty Information

(SEE WRITTEN WARRANTY FOR COMPLETE DETAILS)



The condensed list below is a convenient overview of the written warranties offered on various Café™ appliances described in this document for products manufactured on or after January 1, 2006. For complete warranty details on a specific Café model, visit Café.com or contact your nearest Café reseller, or call Café Factory Service, toll free, 800-432-2737.

Refrigerators, Wine and Beverage Centers, 50 lb./Refrigerator Ice Makers

ALL CAFÉ MODELS

For the period of	Café will replace
One year From the date of the original purchase	Any part in the refrigerator which fails due to a defect in materials or workmanship. During this limited one-year warranty , Café will provide, free of charge , all labor and related service costs to replace the defective part.
Five years From the date of the original purchase	Any part of the sealed refrigerating system (the compressor, condenser, evaporator and all connecting tubing) which fails due to a defect in materials or workmanship. During this limited five-year sealed refrigerating system warranty , Café will also provide, free of charge , all labor and related service costs to replace the defective part.

Ice Makers

FOR REFRIGERATORS

For the period of	Café will replace
One year From the date of the original purchase	Any part in the ice maker which fails due to a defect in materials or workmanship. During this limited one-year warranty , Café will provide, free of charge , all labor and related service costs to replace the defective part.

Ranges, Cooktops, Wall Ovens, Warming Drawers and Hoods

ALL CAFÉ MODELS

For the period of	Café will replace
One year From the date of the original purchase	Any part in the cooking product which fails due to a defect in materials or workmanship. During this limited one-year warranty Café will provide, free of charge , all labor and related service costs to replace the defective part.

Speedcook Ovens with Advantium® Technology

ALL CAFÉ MODELS

For the period of	Café will choose to replace or service
One year From the date of the original purchase	Any part of the oven which fails due to a defect in materials or workmanship. During this limited one-year warranty , Café will provide, free of charge , all labor and related service costs to replace the defective part.
Five years From the date of the original purchase	The magnetron tube , if the magnetron tube fails due to a defect in the materials or workmanship. During this five-year limited warranty , you will be responsible for any labor or in-home service costs.

Over-The-Range, Drawer, and Countertop Microwave Ovens

ALL CAFÉ MODELS

For the period of	Café will choose to replace or service
One year From the date of the original purchase	Any part in the microwave which fails due to a defect in materials or workmanship. During this limited one-year warranty , Café will also provide, free of charge , all labor and in-home service costs to replace the defective part.
Five years From the date of the original purchase	The magnetron tube , if the magnetron tube fails due to a defect in the materials or workmanship. During this five-year limited warranty , you will be responsible for any labor or in-home service costs.

Dishwashers and Compactors

ALL CAFÉ MODELS

For the period of	Café will replace
One year From the date of the original purchase	Any part in the dishwasher which fails due to a defect in materials or workmanship. During this limited one-year warranty , Café will provide, free of charge , all labor and related service costs to replace the defective part.

Parts and Accessories

For the period of	Café will replace
One year From the date of the original purchase	Any part or accessory which fails due to a defect in materials or workmanship. During this limited one-year warranty , Café will provide, free of charge , all labor and related service costs to replace the defective part or accessory.

For each product listed

What Café will not cover:

- Service trips to your home to teach you how to use the product
- Improper installation
- Replacement of house fuses or resetting of circuit breakers
- Failure of the product if it is abused, misused or used for anything other than the intended purpose or used commercially
- Damage to product caused by accident, fire, floods or acts of God
- Incidental or consequential damage caused by possible defects with this appliance

EXCLUSION OF IMPLIED WARRANTIES - Your sole and exclusive remedy is product repair as provided in this Limited Warranty. Any implied warranties, including the implied warranties of merchantability or fitness for a particular purpose, are limited to one year or the shortest period allowed by law.

This warranty is extended to the original purchaser and any succeeding owner for products purchased for home use within the USA. In Alaska, the One-Year Warranty excludes the cost of shipping, or service calls to your home. Some states do not allow the exclusion or limitation of incidental or consequential damages. This warranty gives you specific legal rights, and you may also have other rights which vary from state to state. To know what your legal rights are, consult your local or state consumer affairs office or your state's Attorney General.

LIMITED WARRANTY INFORMATION

(SEE WRITTEN WARRANTY FOR COMPLETE DETAILS.)



The condensed list below is a convenient overview of the written warranties offered on various GE Appliances & GE Profile appliances described in this document for products manufactured on or after January 1, 2006. For complete warranty details on a specific GE Appliances or GE Profile model, visit geappliances.com, contact your nearest GE Appliances/GE Profile reseller, or call GE Appliances Factory Service, 800.GE.CARES (800-432-2737).

REFRIGERATORS, FREEZERS, WINE AND BEVERAGE CENTERS

For the period of	GE Appliances will replace
One year From the date of the original purchase	Any part in the refrigerator which fails due to a defect in materials or workmanship. During this limited one-year warranty , GE Appliances will provide, free of charge , all labor and related service costs to replace the defective part.
Five years From the date of the original purchase (GE Profile models ONLY)	Any part of the sealed refrigerating system (the compressor, condenser, evaporator and all connecting tubing) which fails due to a defect in materials or workmanship. During this limited five-year sealed refrigerating system warranty , GE Appliances will also provide, free of charge , all labor and related service costs to replace the defective part on GE Profile™ appliances only.

ICEMAKERS

For Refrigerators

For the period of	GE Appliances will replace
One year From the date of the original purchase	Any part in the icemaker which fails due to a defect in materials or workmanship. During this limited one-year warranty , GE Appliances will provide, free of charge , all labor and related service costs to replace the defective part.

WATER FILTERS

For the period of	GE Appliances will replace
30 days From the date of the original purchase	Any part of the water filter cartridge which fails due to a defect in materials or workmanship during this limited thirty-day warranty .*

RANGES, COOKTOPS, WALL OVENS, WARMING DRAWERS AND HOODS

For the period of	GE Appliances will replace
One year From the date of the original purchase	Any part in the cooking product which fails due to a defect in materials or workmanship. During this limited one-year warranty GE Appliances will provide, free of charge , all labor and related service costs to replace the defective part.

SPEEDCOOK FIVE-IN-ONE OVENS WITH ADVANTIUM® TECHNOLOGY

For the period of	GE Appliances will choose to replace or service
One year From the date of the original purchase	Any part of the oven which fails due to a defect in materials or workmanship. During this limited one-year warranty , GE Appliances will provide, free of charge , all labor and related services costs to replace the defective part.
Five years From the date of the original purchase	The magnetron tube , if the magnetron tube fails due to a defect in the materials or workmanship. During this five-year limited warranty , you will be responsible for any labor or in-home service costs.

OVER-THE RANGE AND COUNTERTOP MICROWAVES

For the period of	GE Appliances will choose to replace or service
One year From the date of the original purchase	In the event of service , GE Appliances will provide any part of the microwave which fails due to a defect in materials or workmanship. During this limited one-year warranty , GE Appliances will also provide, free of charge , all labor and related service costs to replace the defective part when the unit is serviced.

DISHWASHERS AND COMPACTORS

For the period of	GE Appliances will replace
One year From the date of the original purchase	Any part in the dishwasher or compactor which fails due to a defect in materials or workmanship. During this limited one-year warranty , GE Appliances will provide, free of charge , all labor and related service costs to replace the defective part.

DISPOSERS

For the period of	GE Appliances will replace
One year From the date of the original purchase	Models GFC320 and GFC325: The entire disposer if there is a defect in materials or workmanship relating to functional parts only (appearance parts are excluded). During this limited one-year warranty , GE Appliances will also provide, free of charge , all labor charges related to replacing the original disposer along with the replacement disposer within the first year.
Additional one year From the date of the original purchase	Models GFC520V, GFC525V: If there is a defect in materials or workmanship relating to functional parts only (appearance parts are excluded). During this one-year extended limited warranty period , you will be responsible for all installation charges related to the replacement disposer.
Additional two years From the date of the original purchase	Models GFC530V, GFC535V: If there is a defect in materials or workmanship relating to functional parts only (appearance parts are excluded). During this two-year extended limited warranty period , you will be responsible for all installation charges related to the replacement disposer.
Additional four years From the date of the original purchase	Models GFC720V, GFB760V: If there is a defect in materials or workmanship relating to functional parts only (appearance parts are excluded). During this four-year extended limited warranty period , you will be responsible for all installation charges related to the replacement disposer.
Additional six years From the date of the original purchase	Model GFC1020V: If there is a defect in materials or workmanship relating to functional parts only (appearance parts are excluded). During this six-year extended limited warranty period , you will be responsible for all installation charges related to the replacement disposer.
Three years From the date of the original purchase	Model GREEN05P: The entire disposer if there is a defect in materials or workmanship relating to functional parts only (appearance parts are excluded). During this limited three-year warranty , GE Appliances will also provide, free of charge , all labor charges related to replacing the original disposer along with the replacement disposer within the first year.

*If your GE Appliances part fails because of a manufacturing defect within thirty days from the date of original purchase for use, we will give you a new or, at our option, a rebuilt part without charge. Return the defective part to the parts supplier from whom it was purchased together with a copy of the "proof of purchase" for the part. If the part is defective and shows no signs of abuse, it will be exchanged. The warranty does not cover the failure of parts which are damaged while in your possession, are abused, or have been installed improperly. It does not cover the cost of returning the part to the supplier from whom it was purchased nor does it cover the cost of labor to remove or install it to diagnose the fault. It does not cover parts used in products in commercial use except in the case of air conditioning equipment. In no event shall GE Appliances be liable for consequential damages. Warrantor: GE Appliances

GE Appliances has a policy of continuous improvement of its products and reserves the right to change materials and specifications without notice.

(continued on next page)

ELECTRIC WATER HEATER

For the period of	GE Appliances will replace
One year From the date of the original purchase	Any part in the Water Heater which fails due to a defect in materials or workmanship. During this limited one-year warranty , GE Appliances will reimburse registered service providers, or will reimburse consumers for documented out of pocket costs for parts and/or labor for professional service at a predetermined rate as found on the GE Appliances Website GEAppliances.com/water heater , unless service provided to replace defective parts is determined to be a result of improper installation or maintenance.
Second through Eighth, Tenth or Twelfth Year From the date of the original purchase	Any part of the Water Heater which fails due to a defect in materials or workmanship. During this limited second through the end of the warranty period , labor and related service to replace the defective part are not included. *Warranty is based on the 6th and 7th digit of model number located on rating plate (e.g.: GE50T08BAM has a part warranty of 8 years).

TANKLESS ELECTRIC WATER HEATERS

For the period of	GE Appliances will replace
Five years From the date of the original purchase	We will replace: The entire water heater if there is a defect in materials or workmanship relating to functional parts only. During this warranty period , labor and related service to install the new water heater or remove the defective water heater is not covered under this warranty . The replacement unit is warranted for the remainder of your water heater's original five-year warranty period . The replacement unit may either be a new unit or a refurbished unit.

ATMOSPHERIC GAS WATER HEATER

For the period of	GE Appliances will replace
One year From the date of the original purchase	We will replace: Any factory specified part of the water heater which fails due to a defect in materials or workmanship. During this limited one-year warranty , we will also provide, free of charge, all labor and related service to replace the defective part. For the period of second through eighth, tenth or twelfth year from the date of the original purchase. We will replace: Any part of the water heater which fails due to a defect in materials or workmanship. During this limited second through the end of the warranty period, labor and related service to replace the defective part are not included. *Warranty is based on the 6th and 7th digit of model number located on rating plate (e.g.: GE50T08BAM has a part warranty of 8 years).

SOLAR WATER HEATER

For the period of	GE Appliances will replace
One year From the date of the original purchase	Any part in the Water Heater which fails due to a defect in materials or workmanship. During this limited one-year warranty , GE Appliances will reimburse registered service providers, or will reimburse consumers for documented out-of-pocket costs for parts and/or labor for professional service at a predetermined rate as found on the GE Appliances Website GEAppliances.com/water heater , unless service provided to replace defective parts is determined to be a result of improper installation or maintenance.
Second through Fifth Year From the date of the original purchase	Any part in the Water Heater which fails due to a defect in materials or workmanship. During this limited second through year five warranty period , labor and related service to replace the defective part are not included.
Sixth through Tenth Year From the date of the original purchase	50% of the cost of any part , of the water heater which fails due to defect in materials or workmanship. During this sixth through the end of the warranty period , labor and related service to replace the defective part are not included. Warranty is based on the 6th and 7th digit of model number located on rating plate (e.g.: GE50T10BAM has a part warranty of 10 years).

WATER SOFTENERS

For the period of	GE Appliances will replace
One year From the date of the original purchase	Any part of the Water Softening System which fails due to a defect in materials or workmanship. During this limited one-year warranty , GE Appliances will provide, free of charge , all labor and related service costs to replace the defective part.
Second through third year From the date of the original purchase	Electronic Monitor , if the Electronic Monitor fails due to a defect in materials or workmanship. During this additional two-year limited warranty , you will be responsible for any labor and related service costs.
Second through tenth year From the date of the original purchase	Cabinet (Brine Tank) and Resin Tank , if either of these parts fail due to a defect in materials or workmanship. During this additional nine-year limited warranty , you will be responsible for any labor and related service costs.

WASHERS

For the period of	GE Appliances will replace
One year From the date of the original purchase	Any part in the washer which fails due to a defect in materials or workmanship. During this limited one-year warranty , GE Appliances will provide, free of charge , all labor and related service costs to replace the defective part.
Ten years From the date of the original purchase	Models GFW850, GTW840/845, GTW720/725, GTW680/685, GFW650, GFW550 and GFW510: The motor , if it should fail due to a defect in materials or workmanship. During this additional nine-year limited warranty , you will be responsible for any labor and related service costs.

TOP LOAD WASHERS

For the period of	GE Appliances will replace
One year From the date of the original purchase	Any part of the washer which fails due to a defect in materials or workmanship. During this limited one-year warranty , we will also provide, free of charge , all labor and related service to replace the defective part.
Warranties for GTW525 model only:	
Five years From the date of the original purchase	Any part of the washer which fails due to a defect in materials or workmanship. During this limited five-year warranty , we will also provide, free of charge , all labor and related service to replace the defective part.
Ten years From the date of the original purchase	The motor , if it should fail due to a defect in materials or workmanship. During this additional nine-year limited warranty , you will be responsible for any labor and related service costs.
Lifetime of Product From the date of the original purchase	The stainless steel basket , if it should fail due to rust or corrosion of the stainless steel. During this additional LIFETIME limited warranty you will be responsible for any labor and related service costs.

DRYERS

For the period of	GE Appliances will replace
One year From the date of the original purchase	Any part in the dryer which fails due to a defect in materials or workmanship. During this limited one-year warranty , GE Appliances will provide, free of charge , all labor and related service costs to replace the defective part.

REVERSE OSMOSIS FILTRATION SYSTEMS

For the period of	GE Appliances will replace
One year From the date of the original purchase	Any part of the Reverse Osmosis Filtration System (excluding filters) which fails due to a defect in materials or workmanship. During this limited one-year warranty , GE Appliances will provide, free of charge , all labor and related service costs to replace the defective part.

LIMITED WARRANTY INFORMATION (continued)
(SEE WRITTEN WARRANTY FOR COMPLETE DETAILS.)



DUAL-STAGE AND SINGLE-STAGE WATER FILTRATION AND WHOLE HOUSE FILTRATION

For the period of	GE Appliances will replace
One year From the date of the original purchase	Any part of the Water Filtration System (excluding filters) which fails due to a defect in materials or workmanship. During this limited one-year warranty , GE Appliances will provide, free of charge , all labor and related service costs to replace the defective part.

DUAL-STAGE AND SINGLE-STAGE WATER FILTRATION AND WHOLE HOUSE FILTRATION

All GE models starting with GX

For the period of	GE Appliances will replace
One year From the date of the original purchase	Any part of the Water Filtration System (excluding filters) which fails due to a defect in materials or workmanship. During this limited one-year warranty , you will be responsible for any labor and related service costs.

DUAL-STAGE AND SINGLE-STAGE WATER FILTRATION AND WHOLE HOUSE FILTRATION

GE models: UNFCTFBL, UCRING, UCWRENCH, HHRING & HHWRNCH

For the period of	GE Appliances will replace
30 days From the date of the original purchase	Any part of the water filtration accessory that fails due to a defect in materials or workmanship. During this limited 30-day warranty , you will be responsible for any labor and related service costs.

AIR CONDITIONERS

Window

For the period of	GE Appliances will replace
One year From the date of the original purchase	Replacement, repair, or refund of the original retail price for any product which fails due to a defect in materials or workmanship. If the unit is exchanged, the replacement unit is warranted for the remainder of your product's original one-year warranty period. GE Appliances will, at its sole discretion, replace the product with a product of the same or comparable functionality and quality or refund the original retail price.

DEHUMIDIFIERS

For the period of	GE Appliances will replace
One year From the date of the original purchase	Replacement, repair, or refund of the original retail price for any product which fails due to a defect in materials or workmanship . If the unit is exchanged, the replacement unit is warranted for the remainder of your product's original one-year warranty period. GE Appliances will, at its sole discretion, replace the product with a product of the same or comparable functionality and quality or refund the original retail price.

AIR CONDITIONERS

24" Through-the-Wall

For the period of	GE Appliances will replace
Two years From the date of the original purchase	Any part of the air conditioner which fails due to a defect in materials or workmanship. During this limited one-year warranty , GE Appliances will provide, free of charge , all labor and related service costs to replace the defective part.

AIR CONDITIONERS

Zoneline® and Vertical Zoneline

For the period of	GE Appliances will replace
One year From the date of the original purchase	Any part of the air conditioner which fails due to a defect in materials or workmanship. During this limited one-year warranty , GE Appliances will provide, free of charge , all labor and related service costs to replace the defective part.
Five years From the date of the original purchase	Sealed Refrigerating System , if any part of the Makeup Air Module or Sealed Refrigerating System (the compressor, condenser, evaporator, and all connecting tubing) should fail due to a defect in materials or workmanship. During this limited five-year warranty , GE Appliances will provide, free of charge , all labor and related service costs to replace the defective part.
Second through fifth year (Zoneline only) From the date of the original purchase	Fan Motors, Switches, Thermostat, Heater, Heater Protectors, Compressor Overload, Solenoids, Circuit Boards, Auxiliary Controls, Thermistors, Frost Controls, Freeze Sentinel, ICR Pump, Capacitors, Varistors and Indoor Blower Bearing , if any of these parts should fail due to a defect in materials or workmanship. During this additional four-year limited warranty , you will be responsible for any labor and related service costs.
Second through fifth year (vertical Zoneline only) From the date of the original purchase	Fan Motors, Switches, Thermostat, Heater, Heater Protectors, Compressor Overload, Solenoids, Circuit Boards, Auxiliary Controls, Thermistors, Frost Controls, Freeze Sentinel , if any of these parts should fail due to a defect in materials or workmanship. During this additional four-year limited warranty , the customer will be responsible for any labor and related service costs.

AIR CONDITIONERS

26" Built-In

For the period of	GE Appliances will replace
Two years From the date of the original purchase	Any part in the air conditioner which fails due to a defect in materials or workmanship. During this limited two-year warranty , GE Appliances will provide, free of charge , all labor and related service costs to replace the defective part.
Five years From the date of the original purchase	Any part of the Sealed Refrigerating System (compressor, condenser, evaporator, reversing valve and all connecting tubing) which fails due to a defect in materials or workmanship. During this three-year additional warranty , GE Appliances will provide, free of charge , all labor and related service costs to replace the defective part.

PORTABLE AIR CONDITIONER UNITS

For the period of	GE Appliances will replace
One year From the date of the original purchase	Replacement, repair or refund of the original retail price for any product which fails due to a defect in materials or workmanship . If the unit is exchanged, the replacement unit is warranted for the remainder of your product's original one-year warranty period. GE will, at its sole discretion, replace the product with a product of the same or comparable functionality and quality or refund the original retail price .



PARTS AND ACCESSORIES

For the period of	GE Appliances will replace
One year From the date of the original purchase	If your GE Appliances part fails because of a manufacturing defect within one year from the date of original purchase , we will provide a new or, at our option, rebuilt part without charge. Return the defective part to the vendor from whom it was purchased with a copy of the "proof of purchase." If the part is defective it will be exchanged. This warranty does not cover parts which are improperly installed, damaged, abused or used for other than the intended purpose. It does not include cost of returning the part to the vendor from which it was purchased, labor to remove, install or diagnose the failure, parts used in commercial applications, incidental or consequential damage caused by possible defects with the parts. Excludes water filters which offer 30-day warranty.

FOR EACH PRODUCT LISTED

What GE Appliances will not cover:
<ul style="list-style-type: none"> ■ Service trips to your home to teach you how to use the product. ■ Improper installation. ■ Replacement of house fuses or resetting of circuit breakers. ■ Failure of the product if it is abused, misused or used for anything other than the intended purpose or used commercially. ■ Damage to product caused by accident, fire, floods or acts of God. ■ Incidental or consequential damage caused by possible defects with this appliance.

EXCLUSION OF IMPLIED WARRANTIES - Your sole and exclusive remedy is product repair as provided in this Limited Warranty. Any implied warranties, including the implied warranties of merchantability or fitness for a particular purpose, are limited to one year or the shortest period allowed by law.

This warranty is extended to the original purchaser and any succeeding owner for products purchased for home use within the USA. In Alaska, the One-Year Warranty excludes the cost of shipping, or service calls to your home. Some states do not allow the exclusion or limitation of incidental or consequential damages. This warranty gives you specific legal rights, and you may also have other rights which vary from state to state. To know what your legal rights are, consult your local or state consumer affairs office or your state's Attorney General.

LIMITED WARRANTY INFORMATION

(SEE WRITTEN WARRANTY FOR COMPLETE DETAILS.)



The condensed list below is a convenient overview of the written warranties offered on various Haier appliances described in this document for products manufactured on or after January 1, 2006. For complete warranty details on a specific Haier model, visit Haierappliances.com, contact your nearest Haier supplier, or call Haier Customer Care, toll-free, 1-877-337-3639.

REFRIGERATION

REFRIGERATORS

ALL HAIER MODELS

For the period of	Haier will replace
One year from the date of the original purchase	Any part in the refrigerator which fails due to a defect in materials or workmanship. During the limited one-year warranty , Haier will provide, free of charge , all labor and related service costs to replace the defective part.

COOKING

RANGES, COOKTOPS, WALL OVENS, AND HOODS

ALL HAIER MODELS

For the period of	Haier will replace
One year from the date of the original purchase	Any part in the cooking product which fails due to a defect in materials or workmanship. During the limited one-year warranty , Haier will provide, free of charge , all labor and related service costs to replace the defective part.

OVER-THE-RANGE MICROWAVE OVEN

ALL HAIER MODELS

For the period of	Haier will choose to repair or replace
One year from the date of the original purchase	Any part of the microwave oven which fails due to a defect in materials or workmanship. During this limited one-year warranty , Haier will also provide, free of charge , all labor and related service costs to replace the defective part.

DISHWASHERS

DISHWASHER

ALL HAIER MODELS

For the period of	Haier will replace
One year from the date of the original purchase	Any part in the dishwasher which fails due to a defect in materials or workmanship. During the one-year warranty , Haier will provide, free of charge , all labor and related service costs to replace the defective part.

CLOTHES CARE

COMPACT DRYER

ALL HAIER MODELS

For the period of	Haier will replace
One year from the date of the original purchase	Any part in the dryer which fails due to a defect in materials or workmanship. During the one-year warranty , Haier will provide, free of charge , all labor and related service costs to replace the defective part.

WASHER/DRYER COMBINATION

ALL HAIER MODELS

For the period of	Haier will replace
One year from the date of the original purchase	Any part in the washer/dryer which fails due to a defect in materials or workmanship. During the one-year warranty , Haier will provide, free of charge , all labor and related service costs to replace the defective part.
Five years from the date of the original purchase	Any part of the cabinet assembly which fails due to a defect in materials or workmanship. During the five-year warranty , Haier will provide, free of charge , the cabinet assembly should the cabinet rust through. You will be responsible for any labor and related service costs.
Ten years from the date of the original purchase	The inner stainless steel drum if it should fail due to a defect in materials or workmanship. During the ten-year limited warranty , Haier will provide, free of charge , the inner stainless steel wash tub. You will be responsible for any labor and related service costs.

COMFORT PRODUCTS

AIR CONDITIONERS

WINDOW

For the period of	Haier will replace
One year from the date of the original purchase	Replacement, repair, or refund of the original retail price for any product which fails due to a defect in materials or workmanship. If the unit is exchanged, the replacement unit is warranted for the remainder of your product's original one-year warranty period. GE Appliances will, at its sole discretion, replace the product with a product of the same or comparable functionality and quality or refund the original retail price.

THROUGH-THE-WALL

For the period of	Haier will replace
One year from the date of the original purchase	Replacement, repair, or refund of the original retail price for any product which fails due to a defect in materials or workmanship. If the unit is exchanged, the replacement unit is warranted for the remainder of your product's original one-year warranty period. GE Appliances will, at its sole discretion, replace the product with a product of the same or comparable functionality and quality or refund the original retail price.

PORTABLE

For the period of	Haier will replace
One year from the date of the original purchase	Replacement, repair, or refund of the original retail price for any product which fails due to a defect in materials or workmanship. If the unit is exchanged, the replacement unit is warranted for the remainder of your product's original one-year warranty period. GE Appliances will, at its sole discretion, replace the product with a product of the same or comparable functionality and quality or refund the original retail price.

DEHUMIDIFIERS

For the period of	Haier will replace
One year from the date of the original purchase	Replacement, repair, or refund of the original retail price for any product which fails due to a defect in materials or workmanship. If the unit is exchanged, the replacement unit is warranted for the remainder of your product's original one-year warranty period. GE Appliances will, at its sole discretion, replace the product with a product of the same or comparable functionality and quality or refund the original retail price.

LIMITED WARRANTY INFORMATION

(SEE WRITTEN WARRANTY FOR COMPLETE DETAILS.)



The condensed list below is a convenient overview of the written warranties offered on various Hotpoint® appliances described in this document for products manufactured on or after January 1, 2006. For complete warranty details on a specific appliance model, visit hotpoint.com, contact your nearest Hotpoint appliance reseller. Hotpoint is backed by GE Appliances Service and serviced by GE Appliance technicians. You can call GE Appliance Service at 1-800-GECares (1-800-432-2737)

REFRIGERATORS

FOR THE PERIOD OF	HOTPOINT WILL REPLACE
One year From the date of the original purchase	Any part in the refrigerator which fails due to a defect in materials or workmanship. During this limited one-year warranty, Hotpoint will provide, free of charge, all labor and related service costs to replace the defective part.

RANGES

FOR THE PERIOD OF	HOTPOINT WILL REPLACE
One year From the date of the original purchase	Any part in the cooking product which fails due to a defect in materials or workmanship. During this limited one-year warranty, Hotpoint will provide, free of charge, all labor and related service costs to replace the defective part.

MICROWAVE OVENS

FOR THE PERIOD OF	HOTPOINT WILL REPLACE
One year From the date of the original purchase	Any part in the microwave which fails due to a defect in materials or workmanship. During this limited one-year warranty, Hotpoint will provide, free of charge, all labor and related service costs to replace the defective part.

DISHWASHERS

FOR THE PERIOD OF	HOTPOINT WILL REPLACE
One year From the date of the original purchase	Any part in the dishwasher which fails due to a defect in materials or workmanship. During this limited one-year warranty, Hotpoint will provide, free of charge, all labor and related service costs to replace the defective part.

WASHERS

FOR THE PERIOD OF	HOTPOINT WILL REPLACE
One year From the date of the original purchase	Any part in the washer which fails due to a defect in materials or workmanship. During this limited one-year warranty, Hotpoint will provide, free of charge, all labor and related service costs to replace the defective part.

DRYERS

FOR THE PERIOD OF	HOTPOINT WILL REPLACE
One year From the date of the original purchase	Any part in the dryer which fails due to a defect in materials or workmanship. During this limited one-year warranty, Hotpoint will provide, free of charge, all labor and related service costs to replace the defective part.

COMFORT PRODUCTS

FOR THE PERIOD OF	HOTPOINT WILL REPLACE
One year From the date of the original purchase	Any part of the air conditioner which fails due to a defect in materials or workmanship. During this limited one-year warranty, Hotpoint will provide, free of charge, all labor and related service costs to replace the defective part.
Five years From the date of the original purchase	Any part of the sealed refrigerating system (the compressor, condenser, evaporator and all connecting tubing) which fails due to a defect in materials or workmanship. During this limited five-year warranty, Hotpoint will provide, free of charge, all labor and related service costs to replace the defective part.

PARTS AND ACCESSORIES

FOR THE PERIOD OF	HOTPOINT WILL REPLACE
One year From the date of the original purchase	If your GEA part fails because of a manufacturing defect within one year from the date of original purchase, we will provide a new or, at our option, rebuilt part without charge. Return the defective part to the vendor from whom it was purchased with a copy of the "proof of purchase." If the part is defective it will be exchanged. This warranty does not cover parts which are improperly installed, damaged, abused or used for other than the intended purpose. It does not include cost of returning the part to the vendor from which it was purchased, labor to remove, install or diagnose the failure, parts used in commercial applications, incidental or consequential damage caused by possible defects with the parts.

EXCLUSION OF IMPLIED WARRANTIES — Your sole and exclusive remedy is product repair as provided in this Limited Warranty. Any implied warranties, including the implied warranties of merchantability or fitness for a particular purpose, are limited to one year or the shortest period allowed by law.

GE is a trademark of the General Electric Company.
Manufactured under trademark license.

GE Appliances has a policy of continuous improvement
of its products and reserves the right to change
materials and specifications without notice.

WINE STORAGE

USER GUIDE & SERVICE MANUAL

CLEANING, MAINTENANCE, AND MORE



TITAN

SS-FRBW6420BDZ ■ 24" Dual Zone Black Stainless Steel Beverage and Wine Cooler

Table of Contents

Intro	1
-------	---

Safety and Warning

Instructions Before Using	2
Important Safety Instructions	2

Installation

Environmental Requirements	4
Electrical	5
Cutout Dimensions	6
Installation Clearance Requirements	7
Product Dimensions	8
Product Storage	9
Product Specifications	10
General Installation	11
Types of Installation	12
Handle&Shelf Installation	13
Shelf Installation	14

Operation Instructions

Control Operation	15
Sounds	19
Defrosting	19

Maintenance

Cleaning	20
Troubleshooting	22
Warranty	23

Welcome To Titan Appliances

Congratulations on purchasing your Titan appliance! We at Titan offer quality products that compliment your lifestyle. To learn more about our products please visit our website at www.titan-appliances.com.

This manual contains information on how to install, use and maintain your appliance to perform at its peak efficiency.

To safely transport your appliance in the future, please save the original product packaging.

Before contacting customer service, please ensure that you have done the following:

Proof of Purchase:

For future reference, please write down the model number and serial number below.

Model Number:

Serial Number:

Date of Purchase:

Both the model number and the serial number are located on the product label on the back of your unit and are needed for service under warranty. We suggest stapling your receipt to this manual as it serves as the proof of your purchase and will be needed for service under your warranty.

Before contacting customer service, please ensure that you have done the following:

1. If the unit is damaged upon receipt, please contact the retailer or dealer that sold you the appliance right away.
2. Please read this owner's manual and follow the instructions and recommendations to properly install, operate and maintain the unit.
3. Always refer to the trouble-shooting section of this owner's manual as it contains valuable information and suggestions on how to solve common issues.
4. For the latest information on this product and additional troubleshooting suggestions please visit our website at www.titan-appliances.com
5. Should you need any help on the warranty service please contact our customer services at service@titan-appliances.com

Contacts:

Titan Products, LLC

service@titan-appliances.com

SAFETY AND WARNING

Instructions Before Using Your Appliance.

Before use, make sure all packaging labels and materials are removed from the unit. Be sure to keep track of all included parts and pieces before discarding packaging materials. It is advised that you keep the original box and packaging materials in case you are ever to move or ship the appliance in the future.

Clean the interior surface with a clean soft cloth. Allow the unit to stand for at least 24 hours before use; this allows the cooling system time to settle from transit.

This owner's manual is provided for reference use only. Specifications may change without prior notice. Refer to the product label on the back of your unit for the latest technical information.

Important Safety Instructions

Improper handling can cause serious damage to the Titan appliance and/or injury to the user. This appliance is designed for domestic indoor use only. Use of the unit for industrial or commercial or any other purposes will void the warranty.

NOTICE

Please read all instructions before installing, operating, or servicing the appliance.

Use this appliance for its intended purpose only and follow these general precautions with those listed throughout this guide:

SAFETY ALERT DEFINITIONS

Throughout this guide are safety items labeled with a Danger, Warning or Caution based on the risk types:

 **DANGER**

Danger means that failure to follow this safety statement will result in severe personal injury or death.

 **WARNING**

Warning means that failure to follow this safety statement could result in serious personal injury or death.

 **CAUTION**

Caution means that failure to follow this safety statement may result in minor or moderate personal injury, property or equipment damage.

 **DANGER**

This unit contains R600a (Isobutane) which is a flammable hydrocarbon. It is safe for regular use. Do not use sharp objects to expedite defrosting. Do not service without consulting the "R600a specifications" section included in the User Guide. Do not damage the refrigerant circuit.

 **WARNING**

Service must be done by factory authorized service personnel. Any parts shall be replaced with like components. Failure to comply could increase the risk of possible ignition due to incorrect parts or improper service.

 **DANGER**

RISK OF CHILD ENTRAPMENT. Before you throw away your old refrigerator or freezer, take off the doors and leave shelves in place so children may not easily climb inside.

If the unit is being removed from service for disposal, check and obey all federal, state and local regulations regarding the disposal and recycling of refrigeration appliances, and follow these steps completely:

- 1.Remove all consumable contents from the unit.
- 2.Unplug the electrical cord from its socket.
- 3.Remove the door(s) and shelves(s).

INSTALLATION

Environmental Requirements

This model is intended for indoor/interior applications only and is not to be used in installations that are open/exposed to natural elements.

This unit is designed to operate between 50°F and 95°F. Higher ambient temperatures may reduce the unit's ability to reach low temperatures and/or reduce ice production on applicable models.

For best performance, keep the unit out of direct sunlight and away from heat generating equipments.

In climates where high humidity and dew points are present, condensation may appear on outside surfaces. This is considered normal and does not affect the appliance's performance. The condensation will evaporate when the humidity drops.

CAUTION

Damages caused by ambient temperatures of 40°F (4°C) or below are not covered by the warranty.

VACATION REQUIREMENTS

WARNING

- Short vacations: Leave the appliance operating during vacations for less than three weeks.
- Long vacations: If the appliance will not be used for several months, remove all items and turn off the appliance. Clean and dry the interior thoroughly. To prevent odor and mold growth, leave the door open slightly, blocking it open if necessary.

MOVING REQUIREMENTS

WARNING

- Make sure the appliance is empty.
- Secure the shelves with tape.
- Secure the door with tape.
- Turn the adjustable foot up to the base to avoid damage.
- Protect the outside of the appliance with a blanket or similar item.
- Be sure the appliance stays in the upright position during transportation.
- If the appliance is placed on its back or side during transportation, upon reaching the destination, allow it to remain upright for 6 hours before plugging in to avoid damage to internal components.

Electrical



SHOCK HAZARD – Electrical Grounding Required.

Never attempt to repair or perform maintenance on the unit until the electricity has been disconnected.

Never remove the round grounding prong from the plug and never use a two-prong grounding adapter.

Altering, cutting or removing power cord, removing power plug, or direct wiring can cause serious injury, fire, loss of property and/or life, and will void the warranty.

Never use an extension cord to connect power to the unit.

Always keep your working area dry.

NOTICE

Electrical installation must observe all state and local codes. This unit requires connection to a grounded (three-prong), polarized receptacle that has been placed by a qualified electrician.

The unit requires a grounded and polarized 115 V, 60 Hz, 1.5A power supply (normal household current). An individual, properly grounded branch circuit or circuit breaker is recommended.

Cutout Dimensions

PREPARE SITE

Your Titan product has been designed for either free-standing or built-in installation. When built-in, your unit does not require additional air space for top, sides, or rear. However, the front grille must NOT be obstructed, and clearance is required for an electrical connection in the rear.



Unit can NOT be installed behind a closed cabinet door.

When installing the cooler under a counter, follow the recommended spacing dimensions shown.

- The cabinet should allow at least 24" for the width and 34" for the height to accommodate the beverage cooler.
- Once you are ready to install the unit, you must adjust the feet to level the cooler.

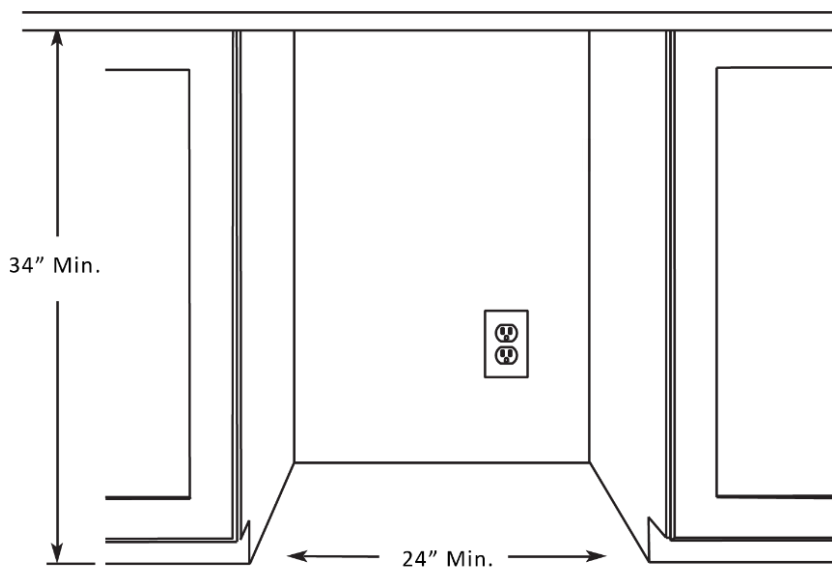

Installation Clearance Requirements

When installing the cooler under a counter, follow the recommended spacing dimensions shown.

- To ensure proper service access and ventilation, allow at least 2-3" of clearance at the back as shown in the diagram.
- The installation should allow the unit to be pulled forward for servicing, if necessary.
- The power cable is located on the back right of the unit and has a length of 72" to accommodate multiple outlet locations.
- An installation next to a wall will require a minimum 2-1/4" door clearance to accommodate the handle

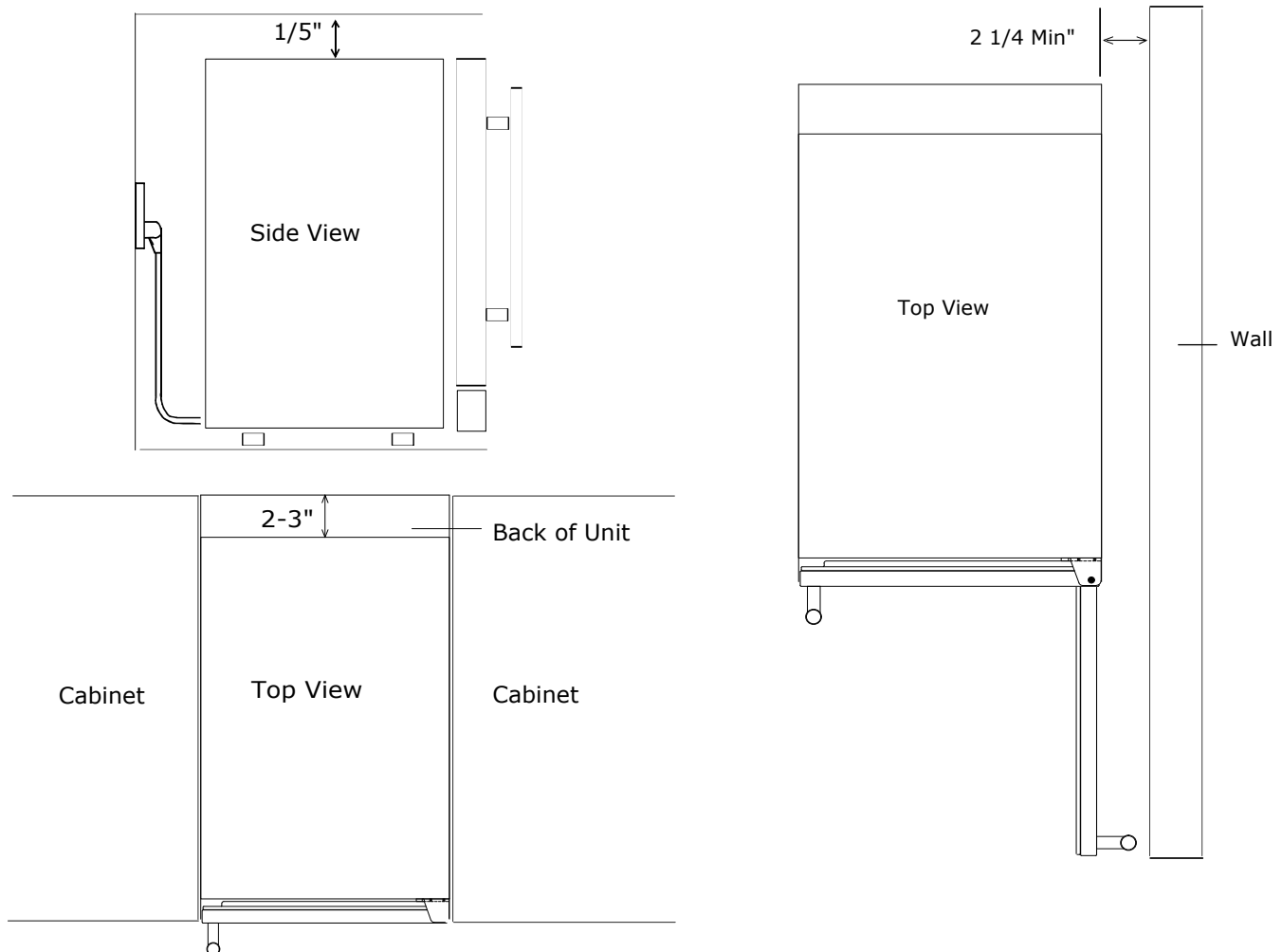

Units have a zero clearance hinge for the door to open 90°, when installed adjacent to cabinets.

Product Dimensions

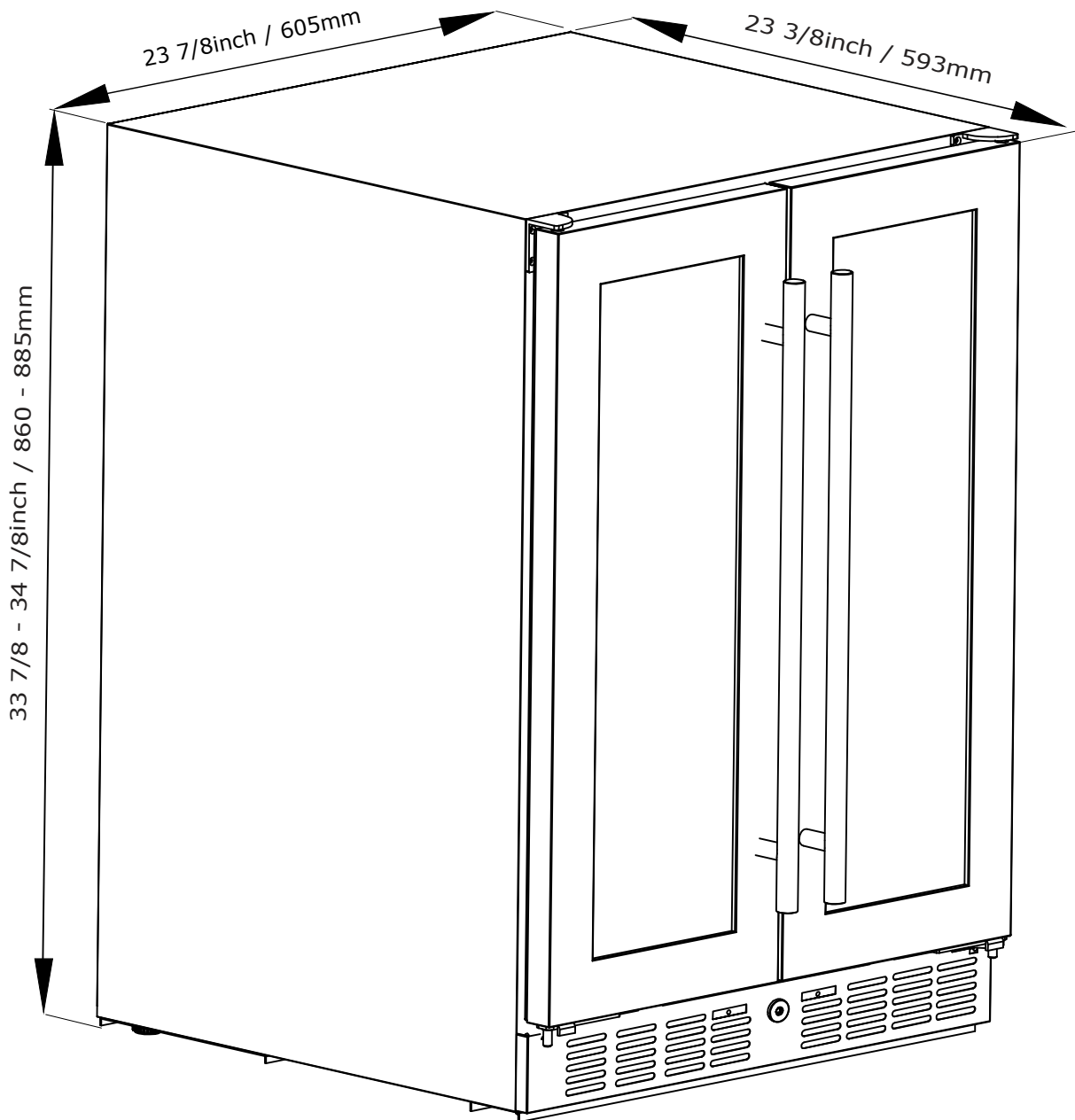

Storage Capacity

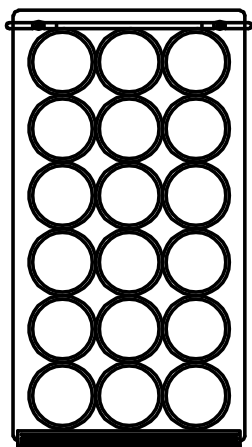
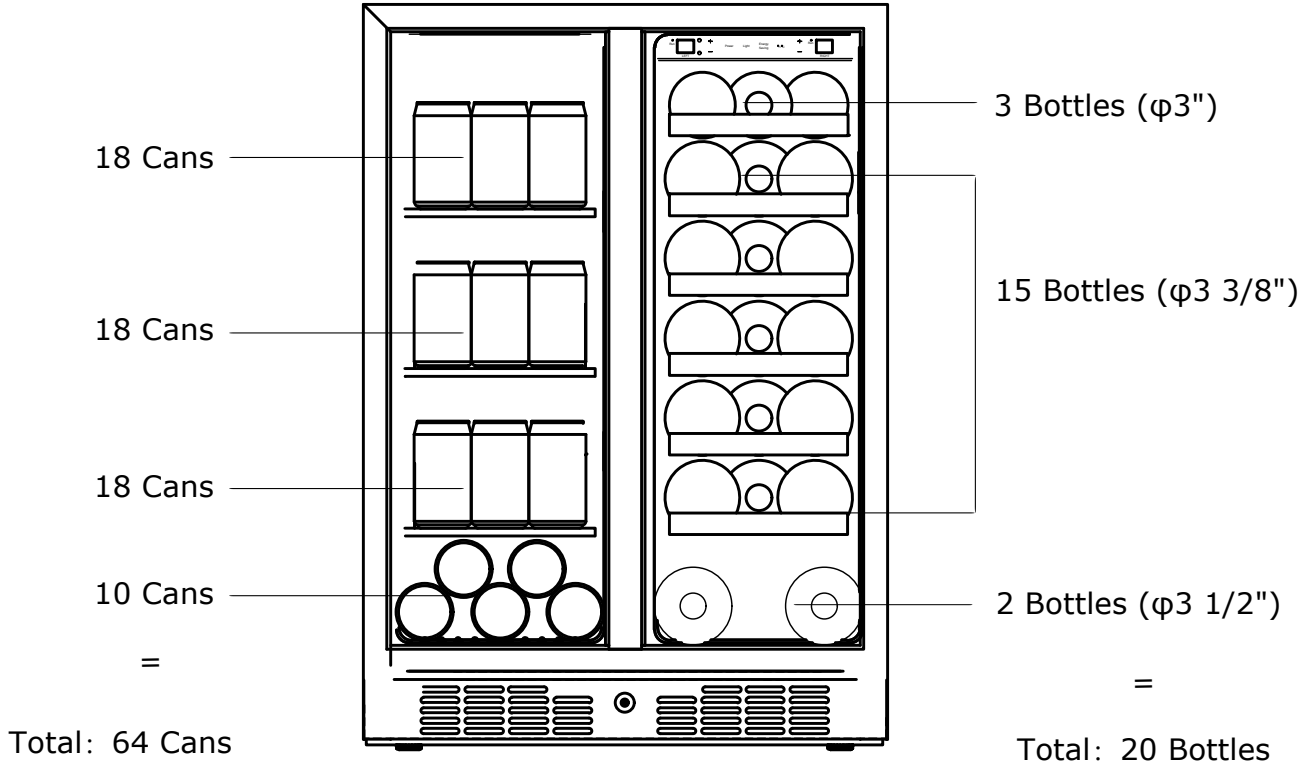

Glass Shelves (3)

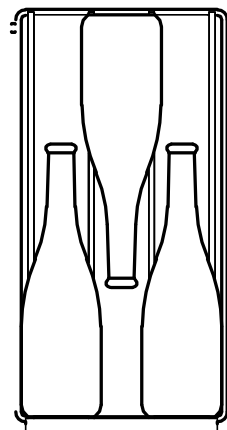
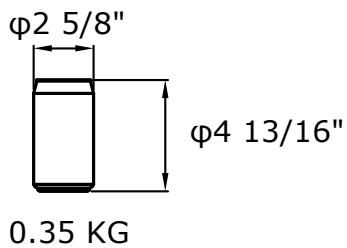

Wine Shelves (6)

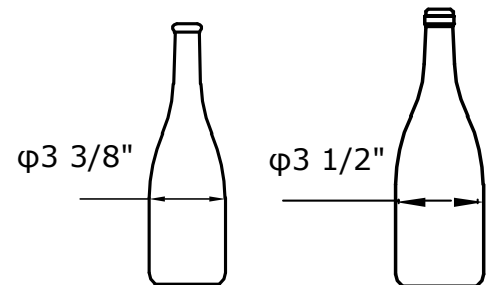

Product Specification

DESCRIPTION OF PRODUCT	Dual Zone Black Stainless Steel French Door Beverage and Wine Cooler
MODEL	SS-FRBW6420BDZ
VOLTAGE / FREQUENCY	AC 115 / 60 Hz
AMPERAGE	1.5 A
COLOR	Black Cabinet with Black Stainless Steel Door
STORAGE CAPACITY	64 cans and 20 bottles
REFRIGERANT	R600a
TEMPERATURE RANGE	Left Beverage Zone: 33° F to 72° F Right Wine Zone: 38° F to 72° F
DIMENSIONS W x H x D (in)	23 7/8" x 33 7/8" - 34 7/8" x 23 3/8"
NET WEIGHT (lbs)	121



Note: Technical data and performance information are provided for reference only. Specifications are subject to change. Check the rating label on the wine refrigerator for the most accurate information.

*The storage capacity is based on standard 750 ml. wine bottles.

General Installation

Before installation, please check and ensure that:

1. The appliance should be installed in accordance with local electrical code requirements.
2. The appliance should be placed in a location that is strong enough to support its total weight –always assume the weight when the appliance is fully loaded.
3. The appliance must be placed in its upright position for at least 24 hours before plugging in and powering on to allow the compressor’s oil to settle.

Unpacking the Appliance

Before installation, please check and ensure that:

1. Always have two or more people to shift and install the unit to avoid back or other injuries.
2. Remove packaging materials carefully. Any shipping tape and glue from your appliance should be removed before using.
3. Never use sharp instruments, rubbing alcohol, flammable fluids, or abrasive cleaners when removing the tape or glue. These products can damage the surface of your appliance.

Appliance Feet Adjustment

There is an adjustable leg on the bottom of each corner of the appliance that can be turned up or down to ensure that the appliance is level. It is important that the appliance is level to minimize noise and vibration.

1. Move the appliance to the designated location.
2. Turn the leveling leg counter-clockwise as far as it will go, until the top of the foot is touching the bottom of the chassis.
3. Slowly turn the leveling leg clockwise until the appliance is level.

IMPORTANT:

Do not remove any safety, warning, or product information labels from your appliance.

Types of Installation:

This appliance can be installed as a free standing or built-in unit. Keep in mind adequate ventilation and access for service is a must.

1. For free-standing installation:

- Allows the installation of the appliance in almost any place you desire.
- Please follow the stated instructions for electrical requirements, and leveling of the appliance.

2. For built-in installation:

- Allows the installation of the appliance under a counter or in a kitchen cabinet. Please ensure that the required clearance space for the appliance is provided.
- Please make sure to allow adequate ventilation space.
- Place the appliance in front of the installation location. Adjust the feet and place the unit flat on the floor or on a platform depending on your installation requirements.
- If the electrical outlet for the appliance is behind the cabinet, plug in the appliance.
- Push the appliance into position.
- Do NOT install the unit behind a closed cabinet door.

Unit Installation Steps

1. Plug in the power/electrical cord.
2. Gently push the unit into position. Be careful not to entangle the cord.
3. Re-check the leveling, from front to back and side to side. Make any necessary adjustments. The unit's top surface should be approximately 1/5" below the countertop.
4. Remove the interior packing material and wipe out the inside of the unit with a clean, water-dampened cloth.
5. To prevent damaging the door or door gasket, make sure the door is open at least 90-degrees when pulling shelves out of the rail compartment.
6. The door opens to a maximum of 135 degrees with a door stop on the bottom hinge preventing the door from opening further.

Attention:

Titan Products recommends allowing the unit to run overnight before loading with product. As warm air rises, the temperature inside the unit tends to be slightly warmer at the top and slightly cooler at the bottom.

When plugged in, the unit will begin operating under the factory default settings. If the unit was turned off during installation, simply press and hold **Power** and the unit will immediately switch on. To turn the unit off, press **Power** again.

Handle Installation

- Open the door and carefully pull the door gasket around the area where the handle is to be installed.
- Insert each Phillips head screw through the gasket side of the door until the screw passes through the door.
- Align the handle with the screws and tighten the screws using a Phillips head screwdriver until the handle is flush against the door frame.
- Carefully press the door gasket into its original position.

Caution: Do not over-tighten the screws as this may cause damage to the handle or to the stainless steel door.

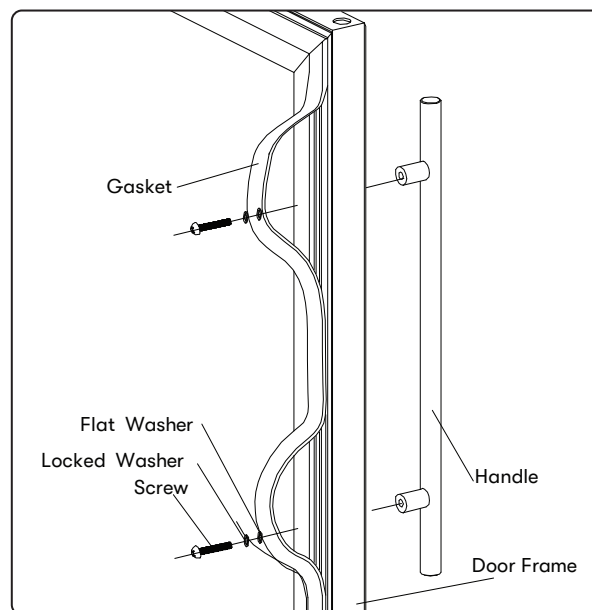

Improper gasket installation will result in condensation

Wire Shelf Removal

1. Open the door completely- make sure to open the door all the way before pulling the shelves out of their track to prevent damaging the door gasket.
2. Remove all contents sitting on the shelf, if any.
3. Tilt one side of the shelf up at a 45-degree angle.
4. Then proceed to pull out the shelf slowly.

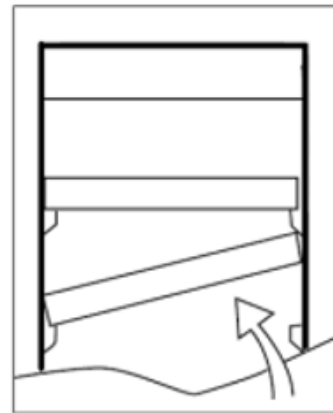
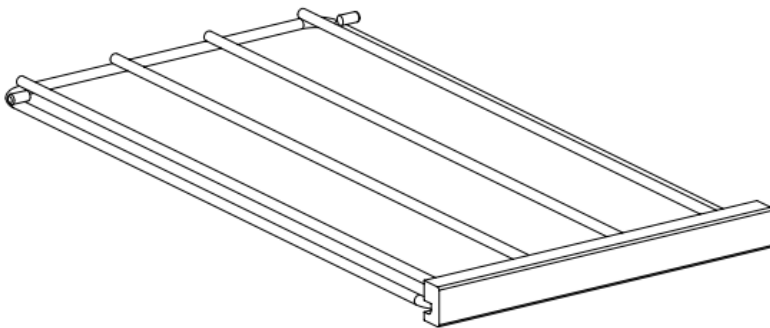

Glass Shelf Removal

1. Open the door completely- make sure to open the door all the way before pulling the shelves out of their track to prevent damaging the door gasket.
2. Remove all contents sitting on the shelf, if any.
3. Tilt one side of the shelf up at a 45-degree angle.
4. Then proceed to pull out the shelf slowly.

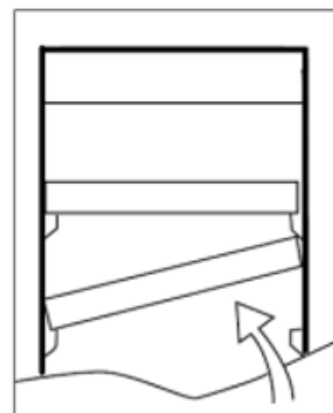
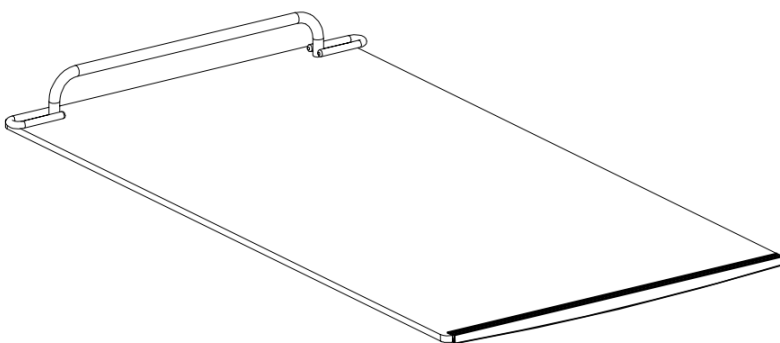

Operation Instruction

Check before operation

- Have you removed all packing materials and tape from the interior and exterior of the unit?
- Have you installed the unit properly by following the installation instructions?
- Has the unit been properly connected to the electrical outlet including proper grounding?
- Have you leveled the unit?
- Is the appliance properly located in an area where the ambient temperature is between 50°F and 95°F all year round?
- Is the clearance of the unit at least 2 to 3 inches at the rear provided for proper air circulation?

Control Operation



This wine cooler has a temperature range for Left zone from 33° F to 72° F (or 0°C to 22°C) ;
Right zone from 38° F to 72° F (or 3°C to 22°C)

FUNCTION	COMMAND	DISPLAY/OPTIONS
Power	Press and hold for 3 seconds	Unit will immediately turn ON or OFF.
Energy Saving	Press to turn this mode ON/OFF	When this mode is turned on, the LED light and display will be turned off .
+	Press and release	Temperature will increase by 1 °F or 1 °C
-	Press and release	Temperature will decrease by 1 °F or 1 °C
Light	Press and release	The interior light will cycle between three colors: blue, amber or white
LED Display		Displays the set temperature
Run		Indicate that compressor is operating
°F/°C	Press and release	The temperature display will change between °F and °C

Power

Press and hold this button for three seconds to power your unit on. Once pressed, the "Run" indicator light will illuminate to indicate the unit is on and running. Press and hold this button for three seconds again and the unit will power off and the "Run" indicator light will turn off.

+ Button

Press this button to increase the setting temperature by one (1) degree increments.

- Button

Press this button to decrease the setting temperature by one (1) degree increments.

Light

Press this button to cycle between three internal light colors.

This refrigerator is equipped with internal lights that can be set to Blue , White or Amber.

You can choose to display each color of light in two different modes: Display mode and Automatic Mode.

*** Display Mode**

The internal lights will stay constantly illuminated whether the door is open or closed. Display Mode is a custom/user-defined function, not a regular day to day function

*** Automatic Mode**

The internal lights will illuminate each time the door is opened and fade off once the door is closed. This feature is triggered by a sensor located on the front vent. This sensor allows the refrigerator to recognize when the door is open or closed.



*The default mode is Automatic Mode. To change between modes, press and hold Light button for 3 seconds. We test every unit that we produce in our factory. Because of this, your model may default to any of the above settings out of the box. Simply cycle through the progression of settings until you reach your desired setting.



Tip: Close the door to determine if the light is currently in Display Mode or Automatic Mode. In Display Mode the lights will remain on, and in Automatic Mode the lights will fade off once the door is closed.

Energy Saving (Sabbath Mode)

Energy Saving mode disables system responses to user-initiated activities and all external functions, including lighting, display and audible alarms. The unit will maintain internal temperatures and set points.

To enable or disable this mode, press the Energy Saving button . The interior light and control display will go dark until the user disables Energy Saving mode.

Although the display will not be visible, the temperature settings will remain active and preserve the internal temperature. Energy Saving mode will remain active until it is disabled by the user.

Temperature Memory

This appliance has a temperature memory function. The temperature setting is automatically saved. In case of a power outage, the temperature setting will remain when power resumes.

Temperature Alarm

If the interior temperature is higher than 81°F (27°C), "HI" is shown on the display panel and the buzzer alarm sounds continuously after one hour. This indicates that the inner temperature is too high. If the inner temperature is lower than 23°F (-5°C), "LO" is shown on the display panel, and the buzzer alarm will go off after fifteen minutes. In either case, immediate attention is advised.

Door Alarm

This unit is equipped with an audible alarm to alert you when the door has been left open.

If at any time the door has been left open for more than 3 minutes, the alarm will sound and will continue to sound until the door is closed completely or the unit is powered off.

 **WARNING**

Allow at least 24 hours for your wine cooler to run before storing your beverages to allow the temperature to acclimate. Whether your wine cooler can reach the actual set temperature depends on the ambient environmental condition

 **CAUTION**

1. If you powered the unit off, please wait at least five (5) minutes before powering it back on.
2. The ambient environmental conditions determine whether your unit can reach the actual set temperature.
3. There is a temperature allowance of +/- 2 degrees Celsius.
4. The unit requires proper airflow to perform at its highest efficiency. Do not block the front grille, or the unit will not perform as expected. Do not install the unit behind a door. When loading your unit, leave space between the evaporator and product loaded. Anything in direct contact with the evaporator is subject to freezing.

Sounds

Some sounds and noises generated by this appliance may not be common to you, however most of these sounds are normal. Hard surfaces like floor and walls may make the sounds seem louder than they actually are.

The following are the sounds you may be experiencing and what's making them.

- Rattling sounds – These may come from the flow of the refrigerant or the water line. Make sure nothing is stored on top of the appliance as this may damage the appliance and also create rattling sounds.
- High-pitched sound – These may come from the efficient compressor.
- Splashing sound – Water running from the evaporator to the water bin.
- Gurgling sound -- May be generated due to the refrigerant flowing in the unit.
- Fan noise – From the condenser fan circulating air within the unit.

Defrosting

The unit automatically defrosts under most ambient conditions and refrigerating settings. However some frost may build up under colder settings.

Additionally, frost may also build up under more humid ambient conditions. Keep the door closed as much as possible and avoid opening the door unnecessarily to minimize frost build-up.

If frost prevents the door from closing properly, power the unit off until the frost melts. Use a soft absorbent towel to dry the unit.

WARNING:

NEVER attempt to remove frost with sharp objects. This may damage the appliance.

Maintenance

Cleaning

Exterior Cleaning

Vinyl Clad (Black)

Clean surfaces with a mild detergent and warm water solution. Do not use solvent-based or abrasive cleaners. Use a soft sponge and rinse with clean water. Wipe with a soft, clean towel to prevent water spotting.

Clean any glass surfaces with a non-chlorine glass cleaner.

Stainless Models

Stainless door panels, handles and frames can discolor when exposed to chlorine gas, pool chemicals, saltwater or cleaners with bleach.

Keep your stainless unit looking new by cleaning with a good quality all-in-one stainless steel cleaner and polish monthly. For best results use Claire® Stainless Steel Polish and Cleaner. Comparable products are also acceptable. Frequent cleaning will remove surface contamination that could lead to rust. Some installations may require cleaning weekly.

Do not clean with steel wool pads.

Do not use stainless steel cleaners or polishes on any glass surfaces.

Clean any glass surfaces with a non-chlorine glass cleaner.

Do not use cleaners not specifically intended for stainless steel on stainless surfaces (this includes glass, tile and counter cleaners.

If any surface discoloring or rusting appears, clean it quickly with Bon-Ami® or Barkeepers Friend Cleanser® and a nonabrasive cloth. Always clean with the grain. Always finish with Claire® Stainless Steel Polish and Cleaner or comparable product to prevent further problems.

Using abrasive pads such as Scotchbrite™ will cause the graining in the stainless steel to become blurred.

Rust not cleaned up promptly can penetrate the surface of the stainless steel and complete removal of the rust may not be possible.

Integrated Models

To clean integrated panels, use household cleaner per the cabinet manufacturer's recommendation.

INTERIOR CLEANING

Disconnect power to the unit.

Clean the interior and all removed components using a mild nonabrasive detergent and warm water solution applied with a soft sponge or non-abrasive cloth.

Rinse the interior using a soft sponge and clean water.

Do not use any solvent-based or abrasive cleaners. These types of cleaners may transfer taste to the interior products and damage or discolor the interior.

 **Warning**

DO NOT use an ice pick or other sharp instrument to help speed up defrosting. These instruments can puncture the inner lining or damage the cooling unit. DO NOT use any type of heater to defrost. Using a heater to speed up defrosting can cause personal injury and damage to the inner lining.

NOTICE

The draining pan was not designed to capture the water created when manually defrosting. To prevent water from overflowing the drain pan, place towels or other absorbent materials over the interior drain trough (under the evaporator) before defrosting.

Troubleshooting

PROBLEM	POSSIBLE CAUSE
Appliance does not operate	<ul style="list-style-type: none"> • Not plugged in. • The appliance is turned off. • Tripped circuit breaker or blown fuse.
Appliance is not cold enough	<ul style="list-style-type: none"> • Check the temperature control setting. • External environment may require a higher setting. • The door is opened too often. • The door is not closed completely. • The door gasket does not seal properly.
Turns on and off frequently	<ul style="list-style-type: none"> • The room temperature is higher than normal. • A large amount of contents has been added to the appliance. • The door is opened too often. • The door is not closed completely. • The temperature control is not set correctly. • The door gasket does not seal properly.
The light does not work	<ul style="list-style-type: none"> • Not plugged in. • Tripped circuit breaker or blown fuse. • The bulb has burned out.
Vibrations	<ul style="list-style-type: none"> • Check to be sure the appliance is level.
The appliance seems to make too much noise	<ul style="list-style-type: none"> • The rattling noise may come from the flow of the refrigerant, which is normal. As each cycle ends, you may hear gurgling sounds caused by the flow of refrigerant in your appliance. Contraction and expansion of the inside walls may cause popping and crackling noises. • The appliance is not level.
The door will not close properly	<ul style="list-style-type: none"> • The appliance is not level. • The door was reversed and not properly re-installed. • The gasket is dirty. • The shelves are out of position.

Titan Products, LLC Limited Warranty

THIS WARRANTY COVERS:

- The original purchaser within all states in the continental United States (excluding Hawaii and Alaska) for one year from the date of purchase against defects in materials and workmanship under normal use and service.
- Titan will be responsible for all transportation costs incurred in the event that service under this warranty is needed for the first 3 months from original purchase date. Consumer will be responsible for freight cost to Titan's service department after 3 months to one year.
- Titan will repair or replace any parts found defective with new, rebuilt, or refurbished parts free of charge.
- Titan reserves the right to request a defective part be returned in exchange for the replacement part.
- After the one year limited warranty, any labor charges or replacement parts will be the responsibility of the original owner of the unit.
- This warranty is not transferable.

THIS WARRANTY DOES NOT COVER:

- Shipping damage and any damage caused by improper packaging for shipment to Titan.
- Cosmetic damage such as scratches and dents or other appearance parts by wear and tear.
- Damage not caused by a defect in material or workmanship while in the possession of a consumer.
- Damage caused by consumer misuse, abuse, tampering, or failure to follow the care and special handling instructions provided in the owner's manual.
- Damage caused by improper installation, maintenance negligence, commercial use, repairs or alterations to the product by anyone not authorized by the manufacturer.
- Acts of God, such as fire, flood, hurricanes, earthquakes and tornadoes.
- Products sold AS Is or from an unauthorized seller.
- Freight and Insurance cost for the warranty service.

Obtaining Warranty Service:

Contact Titan Customer Service at service@titan-appliances.com for troubleshooting, assistance and warranty service. You are required to have your model number, serial number and proof of purchase before contacting Customer Service. Once a Titan Customer Service Representative has confirmed that your product is eligible for warranty service, the product must be returned to an authorized repair center. The returned product must be packaged carefully in its original packaging with the original box and packaging material to avoid shipping damages. Titan is not responsible for damage resulting from mishandling or improper packaging. Do not return a defective product to the place of purchase.

Products received without a return authorization number will be refused.

DISCLAIMER OF IMPLIED WARRANTIES; LIMITATION OF REMEDIES

CUSTOMER'S SOLE AND EXCLUSIVE REMEDY UNDER THIS LIMITED WARRANTY SHALL BE PRODUCT REPAIR OR REPLACEMENT AS PROVIDED HEREIN. IMPLIED WARRANTIES INCLUDING WARRANTIES OF MERCHANTABILITY OR FITNESS FOR A PARTICULAR PURPOSE, ARE LIMITED TO ONE YEAR. WARRANTOR SHALL NOT BE LIABLE FOR CONSEQUENTIAL OR INCIDENTAL DAMAGES SUCH AS PROPERTY DAMAGE AND INCIDENTAL EXPENSES RESULTING FROM ANY BREACH OF THIS WRITTEN LIMITED WARRANTY OR ANY IMPLIED WARRANTY. SOME STATES AND PROVINCES DO NOT ALLOW THE EXCLUSION OR LIMITATION OF INCIDENTAL OR CONSEQUENTIAL DAMAGES, OR LIMITATIONS ON THE DURATION OF IMPLIED WARRANTIES, SO THESE LIMITATIONS OR EXCLUSIONS MAY NOT APPLY TO YOU. THIS WRITTEN WARRANTY GIVES YOU SPECIFIC LEGAL RIGHTS. YOU MAY ALSO HAVE OTHER RIGHTS THAT VARY FROM STATE TO STATE.