



Quote

Number **8033007**

609 Main Avenue
Moorhead, MN 56560
Phone: (218) 233-6104

Order Created: 08/03/2023

Date **08/03/2023**

Page **1**

This Quotation is Valid for 6 Days.

Sold To:

Customer # **477450**
RED LEAF HOMES
JEREMY WALLACE
1809 42ND ST S
MOORHEAD, MN 56560
Phone: (701) 799-9620
Day Phone: (701) 936-3209
redleafhomesfm@outlook.com

Ship To:

RED LEAF HOMES
GE SLATE QUOTE
MOORHEAD, MN 56560
Phone: (701) 799-9620
Day Phone: (701) 936-3209

SalesPerson STEVE	PO Number	Tax Exempt #	Comment GE SLATE QUOTE - NEW RANGE & DISHWASHER MODEL ON QUOTE.
Terms Net 30 Days	Ship Method Delivery		

Model Numbers

Qty	Model Number	Model Description	Unit Amount	Extended
1	GFE26JMMES	GE 36" Std-Depth\26.0 CuFt\3 Dr French\Extrnl Disp	\$1,498.00	\$1,498.00
1	JGS760EPES	GE 30" S/\Gas\5 Burners\Aluminum Griddle\Slf Cln w	\$1,298.00	\$1,298.00
1	GDT670SMVES	GE 24" Built In Dishwasherr	\$629.00	\$629.00
1	JVW5301EJES	GE 30" Chimney Hood\350 CFM\Halogen Lighting	\$549.00	\$549.00
1	JXDC72ES	GE SLATE DUCT COVER 10' CEILIN	\$149.00	\$149.00
1	PEB7227ANDD	PROFILE 1,100 WATT 2.2 CuFt\Sensor	\$479.00	\$479.00
1	JX7227ELES	"Inst Kit\Slate\27"" Width \ Not Connectable	\$249.00	\$249.00

Purchaser agrees that Seller shall retain a purchase money security interest in the above merchandise until payment is made in full. There is no FINANCE CHARGE on accounts paid within 30 days of delivery. All accounts not paid within 30 days of delivery a FINANCE CHARGE is computer by a periodic rate of 1.5% per month or a minimum charge of 50 cents which is an Annual Percentage Rate of 18%. The finance charge is computer 30 days after delivery on the unpaid balance and each 30 day period thereafter. Prices quoted by salespersons are for normal situations and do not cover abnormal circumstances.

Summary

Sub Total	\$4,851.00
Taxable Sub Total	\$4,851.00
Tax 7.875%	\$382.02
Total	\$5,233.02



Model#: GFE26JEMDS

GE® ENERGY STAR® 25.7 Cu. Ft. French-Door Refrigerator

Approx Dimensions (HxWxD):
69 7/8 H x 35 3/4 W x 35 7/8 D

- 25.6 cu. ft. capacity-Easily store large or bulk food items with three full-width shelves and large capacity
- Space-saving icemaker-Located on the door with integrated bins to create more usable storage space
- LED lighting-Find exactly what you've been looking for under crisp, clear lighting
- External controls with actual temperature display, child lock and door alarm-Eliminates the guesswork in setting refrigerator temperatures; conveniently displayed on the dispenser
- Spill-proof shelves-A variety of shelf configurations provide additional options for food storage
- Two humidity-controlled drawers and full-width drawer>Create the right environment for keeping fruits and vegetables fresh, while easily storing wider items like a party platter or a sheet cake
- Quick Space shelf-Quickly slides out of the way to make room for tall items

Warranty Information:

- Warranty Notes: See written warranty for full details
- Labor Warranty: Limited 1-year entire appliance
- Parts Warranty: Limited 1-year entire appliance





Model#: JGS760FPDS

GE® 30" Slide-In Front-Control Convection Gas Range with No Preheat Air Fry

Approx Dimensions (HxWxD):

36 1/4 H x 30 W x 29 1/4 D

- No Preheat Air Fry-Cook healthier, crispier versions of your favorite foods in less time, thanks to an air fryer right in your oven that doesn't require preheating, a basket or a special tray
- Built-in WiFi-This smart oven features built-in WiFi so you can control oven functions with the SmartHQ app on your smart device
- Fit Guarantee-Replace your old 30" free-standing range with a new 30" slide-in model. GE slide-in ranges are guaranteed for an exact fit or GE Appliances will pay up to \$300 toward modifications. [See offer criteria and details](#)
- Edge-to-edge cooktop-A large cooking surface gives you extra room for pots and pans of all sizes and lets cookware move easily from burner to burner
- Extra-large integrated non-stick griddle-Cook up to six grilled cheeses at once on the industry's largest integrated griddle
- 18,000 BTU Power Boil burner-Prepare your favorite pasta dishes faster by boiling water in less time
- Gas convection-Evenly bake foods like roasts and cookies with this helpful feature that uses a fan to circulate heated air

Warranty Information:

- Parts Warranty: Limited 1-year entire appliance
- Labor Warranty: Limited 1-year entire appliance
- Warranty Notes: See written warranty for full details

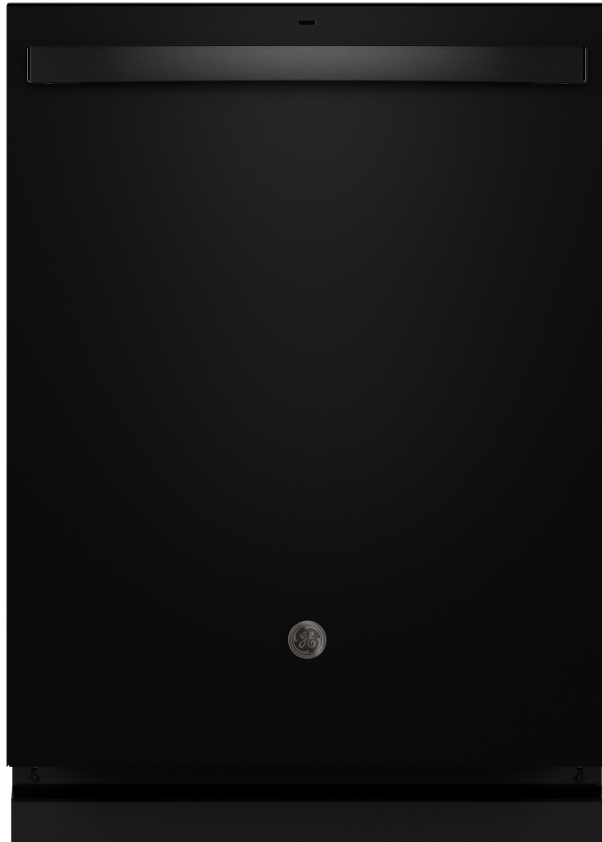

Model#: GDT670SFVDS

GE® ENERGY STAR® Top Control with Stainless Steel Interior Dishwasher with Sanitize Cycle

Approx Dimensions (HxWxD):

34 H x 23 3/4 W x 24 D

- Dry Boost™ Technology-Dry Boost™ Technology outperforms standard heated-dry dishwashers by getting hard-to-dry items like plastics up to 3 times drier when compared to heated dry.
- Third Rack with Removable Silverware Caddy-The versatile Third Rack was redesigned to load more than just silverware with additional space for unique items.
- Deep Clean Silverware Jets-A system of 40 deep-cleaning silverware jets blasts the silverware basket from the bottom up, removing all stuck-on food for sparkling results.
- 4 Bottle Wash Jets-Ensure a deep clean for tall items, narrow glasses, jars and more thanks to this dishwasher with bottle jets. 4 powerful jets direct water and detergent inside to effectively wash hard-to-reach areas.
- Smooth-Glide Upper Rack-This dishwasher with a smooth-glide rack makes loading and unloading smooth and simple. It easily extends on stainless steel ball bearings, so you can make light work of even the heaviest loads.
- Steam + Sani-Save time with a high-temperature cycle that steams and sanitizes. Get a complete wash with no pre-rinsing or soaking necessary and reduce 99.999% of bacteria.
- High Wash Performance-Get a complete wash with no pre-rinse thanks to a variety of wash cycles that provides a powerful clean. No matter how many dishes you load or how dirty they are, rest assured you'll get spotless results every time.

Warranty Information:

- Labor Warranty: Limited 1-year entire appliance
- Warranty Notes: See written warranty for full details
- Parts Warranty: Limited 1-year entire appliance



Model#: JWV5301FJDS

GE® 30" Wall-Mount Pyramid Chimney Hood

Approx Dimensions (HxWxD): 9 7/8 H x 30 W x 18 1/2 D

- Easy do-it-yourself Installation
- 350-CFM venting system with boost-Effectively remove smoke, grease, odor and moisture
- Electronic backlit controls-Add a sophisticated look with this up-front, easy-to-use display
- Dual halogen cooktop lighting-Enjoy better visibility with a brightly lit cooktop and surrounding surface
- Night light-Keep a dim light on for visibility at all hours
- Convertible venting options-Select recirculating or external venting
- Optional remote control (JXRC70)-Control your ventilation lighting and fan speed from anywhere in the kitchen



Model#: UXDC72FJDS

9 (ft.) Ceiling Duct Cover Kit

Approx Dimensions (HxWxD):



Model#: PEB7227ANDD

GE Profile™ 2.2 Cu. Ft. Built-In Sensor Microwave Oven

Approx Dimensions (HxWxD): 14 H x 24 1/8 W x 19 3/4 D

- Built-in microwave-This microwave oven is built-in capable with a sleek matching trim kit
- Glass touch controls-Features a smooth glass design that is easy to operate and easy to clean
- 2.2 cu. ft. capacity-1100 watts (IEC-705 test procedure)
- Sensor cooking controls-Automatically adjusts time and power for delicious cooking results
- Weight and time defrost-Simply enter the weight of the food, and the oven automatically sets the optimal defrosting time and power level or set your desired time for defrosting
- Extra-large 16" turntable-Rotates food throughout the cycle and accommodates large cookware
- Instant On controls-One-touch instant operation

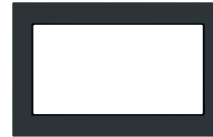

Model#: JX7227FMDS

GE® Required 27" Built-In Trim Kit JX7227FMDS

Approx Dimensions (HxWxD): 18 7/8 H x 26 3/4 W

GFE26JBM/JEM/JMM/JSM/JGM/JYM

GE® ENERGY STAR® 25.6 Cu. Ft. French-Door Refrigerator

DIMENSIONS AND INSTALLATION INFORMATION (IN INCHES)

OVERALL DIMENSIONS	Height to top of door - crown or flat (in.) A	69-7/8
	Height to top of hinge (in.) B	69-3/4
	Height to top of case (in.) C	68-5/8
	Case depth without door (in.) D	29
	Case depth less door handle (in.) E	33-3/8
	Case depth with door handle (in.) F	35-7/8
	Depth with fresh food door open 90° (in.) G	48-3/8
	Width (in.) H	35-3/4
	Width with door open 90° inc. door handle (in.) I	43-3/4
AIR CLEARANCES	Each side (in.)	1/8
	Top (in.)	1
	Back (in.)	2

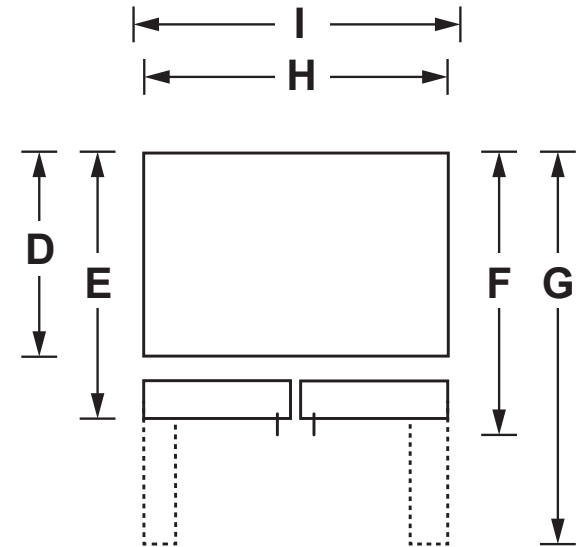
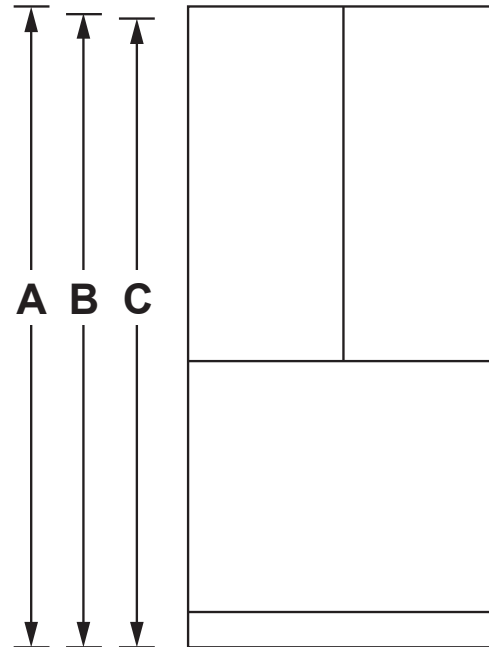

For answers to your Monogram, GE Café™ Series, GE Profile™ Series or GE Appliances product questions, visit our website at geappliances.com or call GE Answer Center® Service, 800.626.2000.



Listed by
Underwriters
Laboratories



As an ENERGY STAR® partner, GE has determined that this product meets the ENERGY STAR guidelines for energy efficiency.

GFE26JBM/JEM/JMM/JSM/JGM/JYM

GE® ENERGY STAR® 25.6 Cu. Ft. French-Door Refrigerator

FEATURES AND BENEFITS

25.6 cu. ft. capacity – Easily store large or bulk food items with three full-width shelves and large capacity

In-the-door icemaker – Frees up valuable space in the fresh-food section for more storage of your favorite foods

Color-matched external Ice and water dispenser – Fills tall bottles, stores and makes ice in the door, saving space

LED lighting – Find exactly what you've been looking for under crisp, clear lighting

Spill-proof shelves – Raised edges help contain spills and make clean up quick and easy

Full-width deli drawer – Allows party trays and larger items to fit easily and remain at the ideal temperature

Quick Space shelf – Quickly slides out of the way to make room for tall items

Advanced water filtration uses XWF replacement filter – Reduces trace pharmaceuticals from water and ice* (* Removes 98% of ibuprofen, atenolol, fluoxetine, progesterone and trimethoprim. These pharmaceuticals are not necessarily in all users' water)

Model GFE26JBMTS – Black stainless

Model GFE26JEMDS – Black slate

Model GFE26JMMES – Slate

Model GFE26JSMSS – Stainless steel

Model GFE26JGMBB – Black

Model GFE26JGMWW – White

Model GFE26JYMFS – Fingerprint resistant stainless

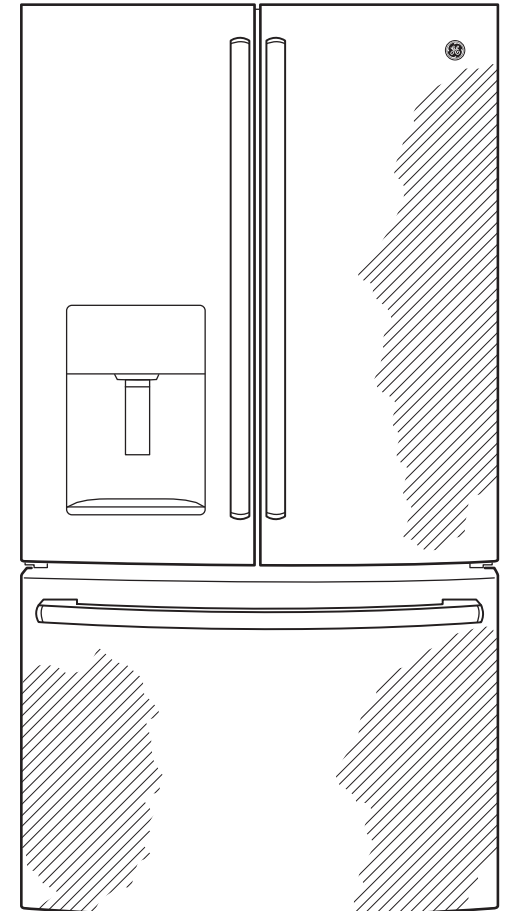

As an ENERGY STAR® partner, GE has determined that this product meets the ENERGY STAR guidelines for energy efficiency.

JGS760BP/DP/EP/SP/FP

GE® 30" Slide-In Front-Control Convection Gas Range with No Preheat Air Fry

DIMENSIONS AND INSTALLATION INFORMATION (IN INCHES)

NOTE: Door handle protrudes 3" from door face.
Cabinets and drawers on adjacent 45° and 90° walls should be placed to avoid interference with the handle.

NOTE: Cabinets installed adjacent to slide-in ranges must have an adhesion spec of at least 194° temperature rating.

INSTALLATION INFORMATION: Before installing, consult installation instructions packed with product for current dimensional data.

For all installations, install the required rear trim to back of range with 4 screws provided.

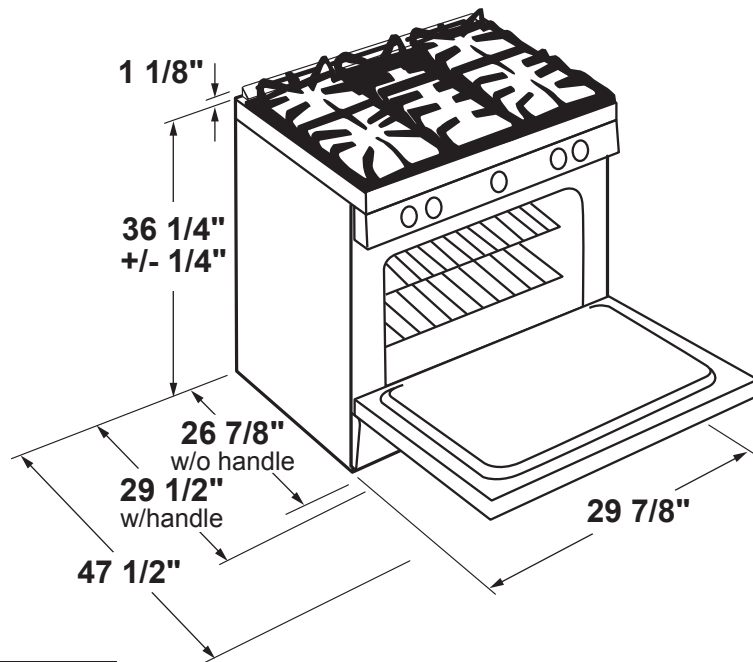

GAS PIPE AND ELECTRICAL OUTLET LOCATIONS

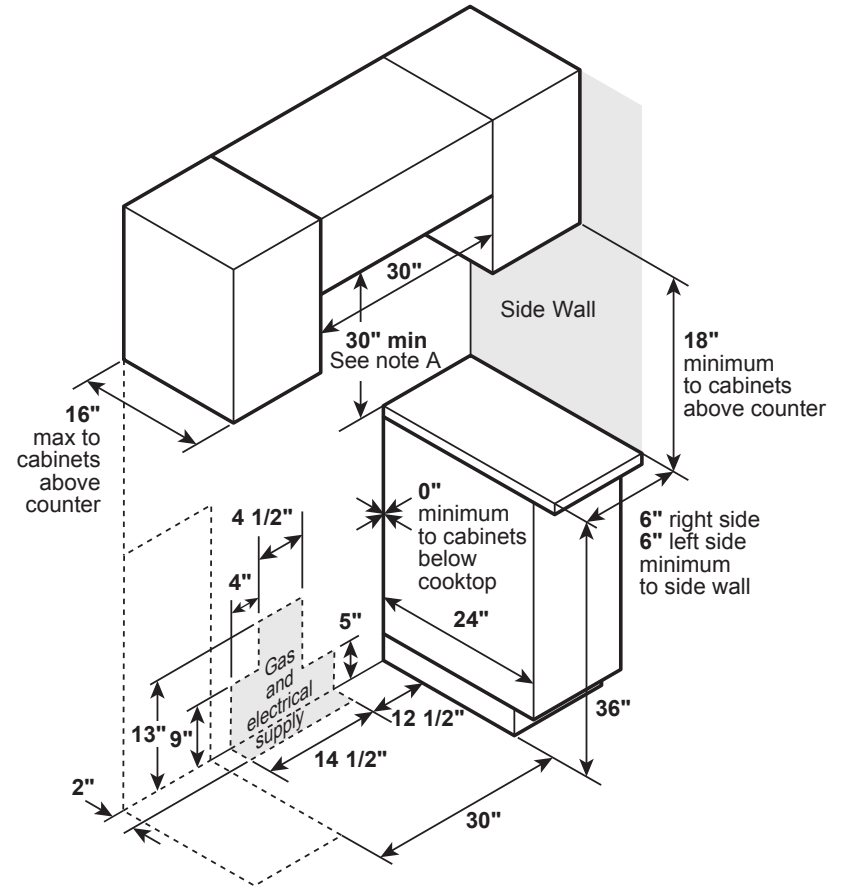

Note A: 30" Minimum to bare cabinet, see installation instructions heights less than 30"



For answers to your Monogram, GE Café™, GE Profile™ or GE Appliances product questions, visit our website at geappliances.com or call GE Answer Center® Service, 800.626.2000.



All GE ranges are equipped with an Anti-Tip device. The installation of this device is an important, required step in the installation of the range.

JGS760BP/DP/EP/SP/FP

GE® 30" Slide-In Front-Control Convection Gas Range with No Preheat Air Fry

FEATURES AND BENEFITS

No Preheat Air Fry – With this air fryer right in the oven, you can cook healthier, crispier versions of your favorite foods. There's no preheat required and it shortens the cook time because every minute counts.

Edge-to-Edge Cooktop – A large, continuous cooking surface gives you extra room for pots and pans of all sizes and lets cookware move easily from burner to burner.

Extra-Large, Integrated, Non-Stick Griddle – Cook up to six grilled cheeses at once on the industry's largest integrated griddle.

18,000-BTU Power Boil Burner – Prepare your favorite pasta dishes faster by boiling water in less time.

Gas Convection – Evenly bake foods like roasts and cookies with this helpful feature that uses a fan to circulate heated air.

Self-Clean with Steam Clean Option – Clean your oven the way you want.

Smooth-Glide Storage Drawer – Drawer opens and closes easily for instant access and extra storage.

10,000-BTU Oval Burner – Large oval fifth burner is ideal for griddle or odd-size cookware.

Heavy-Duty, Dishwasher-Safe Grates – Easily and safely clean grates in the dishwasher or place in the bottom of the self-clean oven.

Precise Simmer Burner – Delicate foods don't burn with low, even heat.

Model JGS760BPTS – Black stainless

Model JGS760DPBB – Black on black

Model JGS760DPWW – White on white

Model JGS760EPES – Slate

Model JGS760SPSS – Stainless steel

Model JGS760FPDS – Black Slate

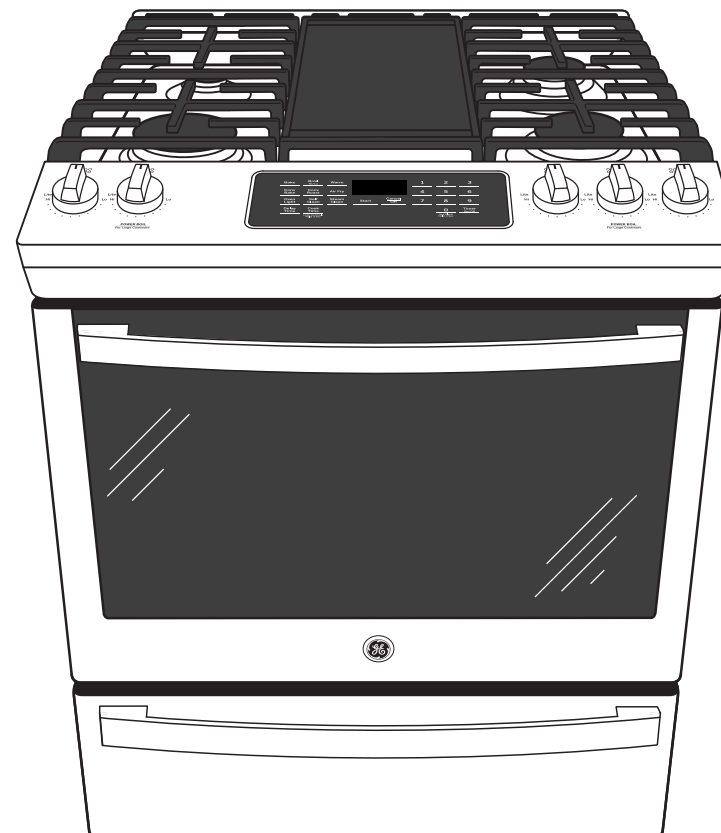

GUARANTEED FIT

Replace your old 30" free-standing range with a new 30" slide-in model. GE slide-in ranges are guaranteed for an exact fit or GE Appliances will pay up to \$300 toward modifications.

Visit geappliances.com for more info



GDT670SGV/SMV/SYV/SFV

GE® Stainless Steel Interior Dishwasher with Hidden Controls

DIMENSIONS AND INSTALLATION INFORMATION (IN INCHES)

ELECTRICAL RATING

Voltage AC.....120
 Hertz.....60
 Total connected load amperage7.8
 Calrod® heater watts max.....800/500

For use on adequately wired 120-volt, 7.8-amp circuit having 2-wire service with a separate ground wire. This appliance must be grounded for safe operation.

INSTALLATION INFORMATION: Before installing, consult installation instructions packed with product for current dimensional data.

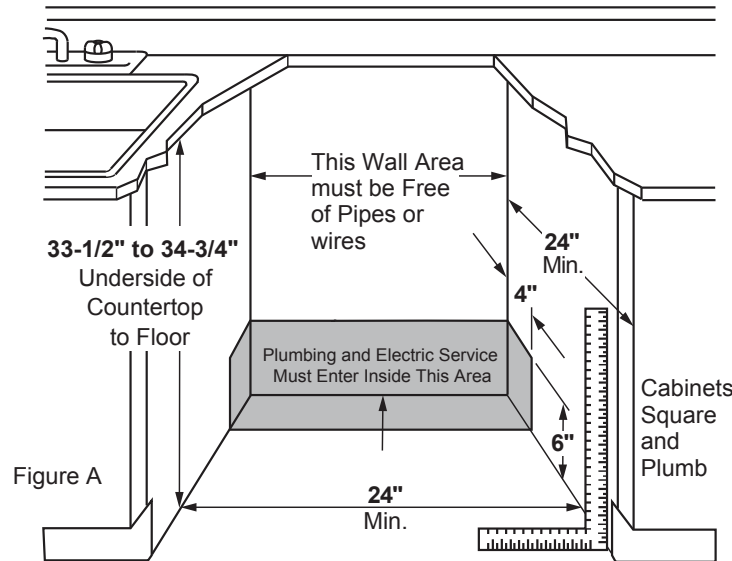
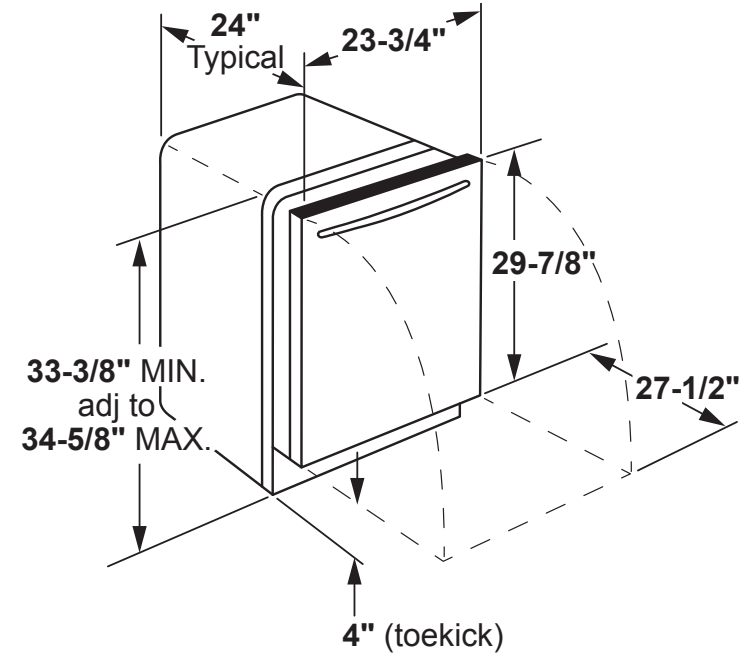

For answers to your Monogram, Café™, GE Profile™ or GE Appliances product questions, visit our website at geappliances.com or call GE Answer Center® Service, 800.626.2000.



Listed by Underwriters Laboratories

GDT670SGV/SMV/SYV/SFV

GE® Stainless Steel Interior Dishwasher with Hidden Controls

FEATURES AND BENEFITS

Dry Boost™ Technology – Dry Boost™ Technology outperforms standard heated-dry dishwashers by getting hard-to-dry items like plastics up to 3 times drier when compared to heated dry.

Third Rack with Removable Silverware Caddy – The versatile Third Rack was redesigned to load more than just silverware with additional space for unique items.

Deep Clean Silverware Jets – A system of deep-cleaning silverware jets blasts the silverware basket from the bottom up, removing all stuck-on food for sparkling results.

4 Bottle Wash Jets – Ensure a deep clean for tall items, narrow glasses, jars and more thanks to this dishwasher with bottle jets. 4 powerful jets direct water and detergent inside to effectively wash hard-to-reach areas.

Smooth-Glide Upper Rack – This dishwasher with a smooth-glide rack makes loading and unloading smooth and simple. It easily extends on stainless steel ball bearings, so you can make light work of even the heaviest loads.

Steam + Sani – Save time with a high-temperature cycle that steams and sanitizes. Get a complete wash with no pre-rinsing or soaking necessary and reduce 99.999% of bacteria.

High Wash Performance – Get a complete wash with no pre-rinse thanks to a variety of wash cycles that provides a powerful clean. No matter how many dishes you load or how dirty they are, rest assured you'll get spotless results every time.

Active Flood Protect – This dishwasher features Active Flood Protect, which prevents potential overflows for greater peace of mind. It works by using a water leak detector to sense when water is too high, pumping it out until a safe level is reached.

Reliable Performance – Enjoy trusted performance from a trusted brand with this American-made, dependable dishwasher that provides totally clean and dry dishes with every cycle.

Piranha™ Hard Food Disposer – The Piranha™ Hard Food Disposer lets you use your dishwasher without pre-rinsing. Its stainless steel impellers rotate to pulverize food particles and an anti-jamming design makes sure wash arms stay unclogged.

45 dBA Dishwasher – Enjoy a peaceful kitchen and a powerful wash with this super-silent 45 dBA dishwasher.

Extra-Large Capacity – This extra-large capacity dishwasher has enough space for 16 place settings and large dish-are, making cleanup easy after large gatherings.

Optional WiFi – Monitor this dishwasher with a smartphone and a WiFi adapter (sold separately) to enjoy a smart dishwasher experience. Simply attach the adapter and start using the SmartHQ™ app to control and monitor your unit remotely. You can even reorder detergent.

1-Hour Wash Cycle – Unload spotless plates, glasses, pots and pans without waiting hours for the dishwasher to finish with this one-hour dishwasher cycle.

AutoSense Cycle – This energy-saving dishwasher has an AutoSense Cycle that detects soil level and amount of dishes before automatically adjusting the wash setting for the ultimate clean.

Wash Zones – Wash a true half-load in the upper or lower rack whenever you need to thanks to this dishwasher with wash zones. The feature works in combination with most cycles, saving you time and conserving energy.

Flush Installation – Cabinet-depth flush installation ensures your dishwasher blends in with the design of your kitchen without sacrificing space for dishes inside.

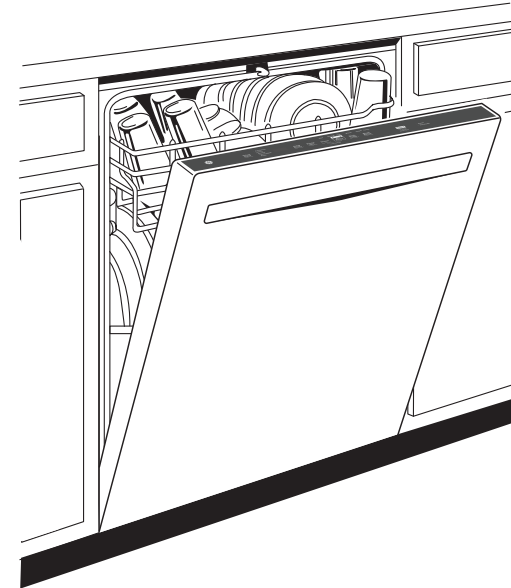

Model GDT670SGVBB – Black

Model GDT670SGVWW – White

Model GDT670SMVES – Slate

Model GDT670SFVDS – Black Slate

Model GDT670SYVFS – Fingerprint Resistant Stainless



JVW5301SJ/EJ/BJ/FJ

GE® 30" Wall-Mount Pyramid Chimney Hood

DIMENSIONS AND INSTALLATION INFORMATION (IN INCHES)

INSTALLATION INFORMATION:

Before installing, consult Use & Care/installation instructions packed with product for current dimensional data.

OPTIONAL ACCESSORIES

UXDC72SJSS/FJDS/BJTS – 9(ft.) Ceiling Duct Cover Kit

UXDC53SJSS/EJES/BJTS/FJDS – 10(ft.) Ceiling Duct Cover Kit

For 30" distance from counter to hood:

Below 8'-4" ceiling height – no duct cover required

8'-4" – 9'-6" ceiling height – use UXDC72SJSS/FJDS/BJTS

Above 9'-7" ceiling height – use UXDC53SJSS/EJES/BJTS/FJDS

Refer to Installation Instructions for exact specifications

UXRC70 – Remote Control

JXCF72 – Charcoal Filter (needed if used in recirculation mode)

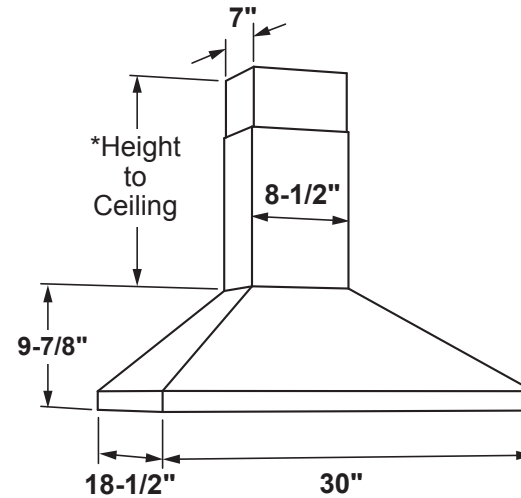

30" Models Require a 30"-Wide Opening

*The supplied duct cover fits 7'-4" to 9'-0" ceiling heights (10' with optional high ceiling kit UXDC53)

AMP RATING	
120V	2.5

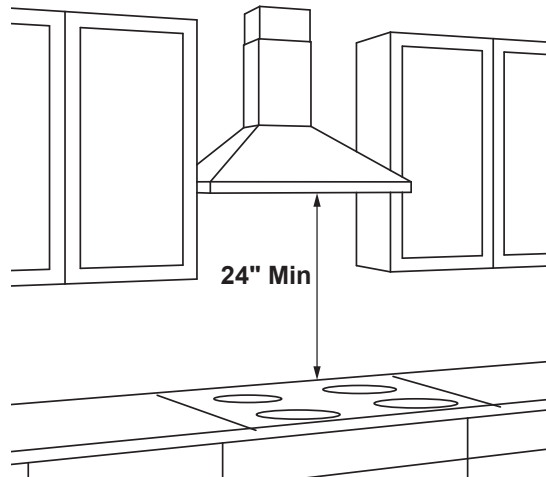

The vent hood must be installed 24" min. above the cooking surface. For optimal performance, installing the hood more than 38" above the cooking surface is not recommended. The hood installation height above the cooking surface depends upon ceiling height. The telescopic duct cover conceals the ductwork running from the top of the hood to the ceiling.

NOTE: Installation height should be measured from the cooking surface to the lowest part of the hood. This hood may be installed onto a wall and vented to the outdoors, or it can be installed for recirculating operation. Parts for recirculating operation are supplied with the hood. However, when installed for recirculating operation, the optional charcoal Filter JXCF72 will need to be purchased separately.



For answers to your GE Profile™ Series or GE Appliances product questions, visit our website at geappliances.com or call GE Answer Center® Service, 800.626.2000.



Specification Revised 01/20

JVW5301SJ/EJ/BJ/FJ

GE® 30" Wall-Mount Pyramid Chimney Hood

FEATURES AND BENEFITS

350-CFM venting system with boost – Effectively remove smoke, grease, odor and moisture

Electronic backlit controls – Add a sophisticated look with this up-front, easy-to-use display

Dual halogen cooktop light – Enjoy better visibility with a brightly lit cooktop and surrounding surface

Night light – Keep a dim light on for visibility at all hours

Convertible venting options – Select recirculating or external venting

Remote control option – Control your ventilation lighting and fan speed from anywhere in the kitchen

Model JVW5301SJSS – Stainless steel

Model JVW5301EJES – Slate

Model JVW5301BJTS – Black stainless

Model JVW5301FJDS – Black slate

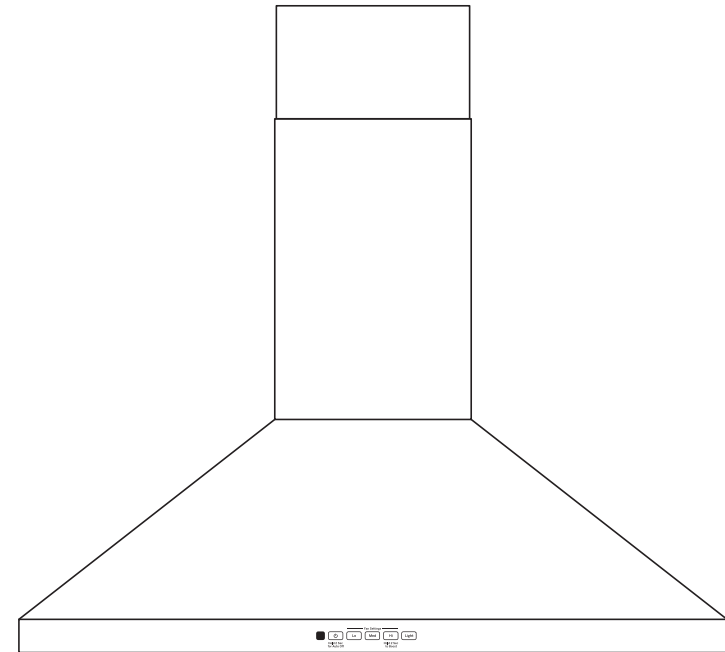

PEB7227ANDD

GE Profile™ Series 2.2 Cu. Ft. Built-In Sensor Microwave Oven

DIMENSIONS AND INSTALLATION INFORMATION (IN INCHES)

EXTERIOR DIMENSIONS (IN INCHES)

W x H x D	24 1/8" x 14" x 19 3/4"
-----------	-------------------------

ACCESSORY TRIM KITS FOR GE MICROWAVE OVENS (AVAILABLE AT ADDITIONAL COST)

For a custom built-in appearance, these kits allow built-in installation of the microwave oven into a wall or cabinet alone and are U.L. approved for installation over a GE single electric wall oven. These kits should not be installed over a gas wall oven.

NOTE: 120V, 60-cycle, grounded power receptacle location optional on back within cabinet opening.

COLOR	TRIM KIT	SIZE	Z	MAX. HEIGHT
Stainless Steel	JX7227SLSS	27"	26 7/8"	18 7/8"
Slate	JX7227ELES	27"	26 7/8"	18 7/8"
Stainless Steel	JX7230SLSS	30"	29 3/4"	18 7/8"
Slate	JX7230ELES	30"	29 3/4"	18 7/8"
Black Stainless	JX7227BLTS	27"	26 7/8"	18 7/8"
Black Slate	JX7227FMDS	27"	26 7/8"	18 7/8"
Black Stainless	JX7230BLTS	30"	29 3/4"	18 7/8"
Black Slate	JX7230FMDS	30"	29 3/4"	18 7/8"

INSTALLATION INFORMATION: This information is not intended to be used for installing unit described. Before installing, consult installation instructions packed with product/kit for current dimensional data. For ADA compliance, the microwave must be installed no higher than 36 1/4".

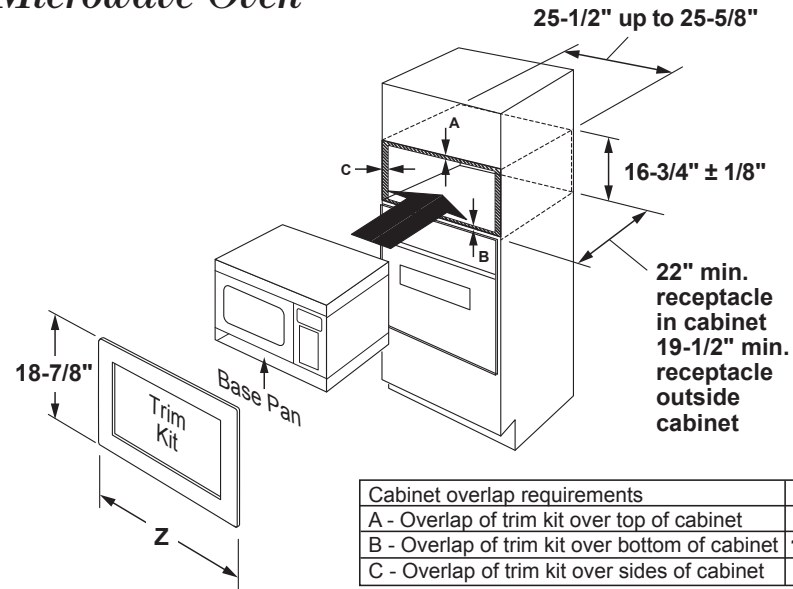

Cabinet overlap requirements	30"	27"
A - Overlap of trim kit over top of cabinet	1"	1"
B - Overlap of trim kit over bottom of cabinet	1-1/8"	1-1/8"
C - Overlap of trim kit over sides of cabinet	2-1/8"	5/8"

NOTE: Allow an additional inch of clearance beyond trim kit frame on all sides to prevent the trim kit from blocking any outside adjoining cabinets/obstructions. Reference below drawing.

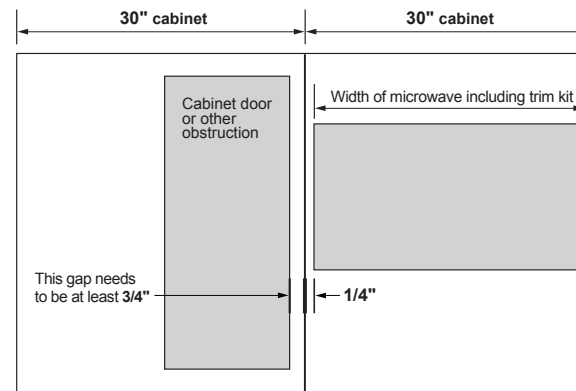

For answers to your Monogram, GE Café™ Series, GE Profile™ Series or GE Appliances product questions, visit our website at geappliances.com or call GE Answer Center® Service, 800.626.2000.



Specification Revised 8/19

PEB7227ANDD

GE Profile™ Series 2.2 Cu. Ft. Built-In Sensor Microwave Oven

FEATURES AND BENEFITS

2.2 cu. ft. capacity – 1100 watts (IEC-705 test procedure)

Sensor cooking controls – Automatically adjusts time and power

Built-in trim kit – Custom appearance and built-in convenience (available at additional cost)

Weight and time defrost – Simply enter the weight of the food, and the oven automatically sets the optimal defrosting time and power level or set your desired time for defrosting

Extra-large 16.5" turntable – Rotates food throughout the cycle and accommodates large cookware

Instant on controls – One-touch instant operation

Control lockout – Helps prevent accidental activation

Add 30 seconds – Add 30 seconds of microwave cooking time

Kitchen timer – Minute timer helps keep you on track

Model PEB7227ANDD – Gray

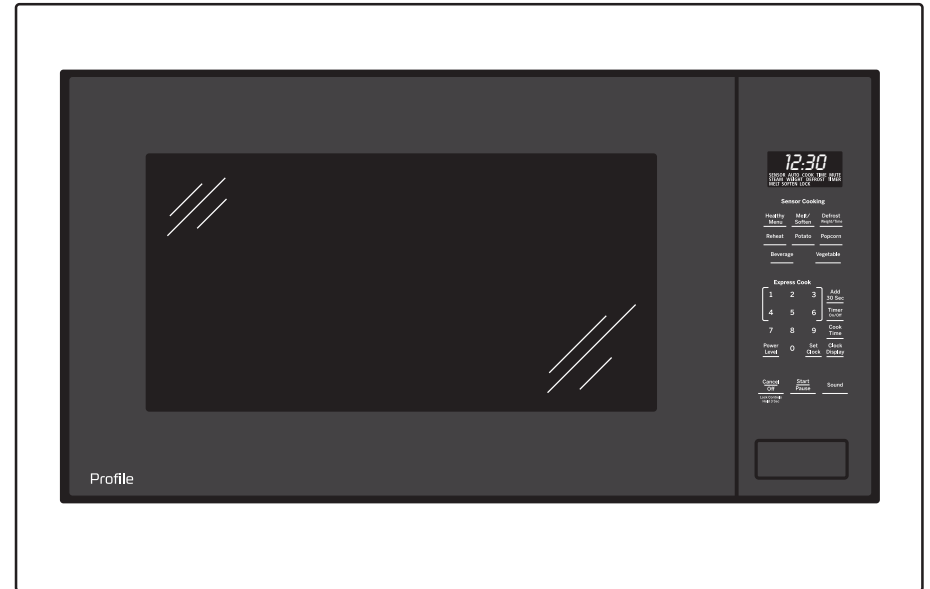



GE APPLIANCES
a Haier company

WARRANTY INFORMATION

DISCOVER OUR APPLIANCE BRANDS

MONOGRAM

C A F É



Profile™

Haier

Hotpoint.

LIMITED WARRANTY INFORMATION

(SEE WRITTEN WARRANTY FOR COMPLETE DETAILS)



The condensed list below is a convenient overview of the written warranties offered on various Monogram appliances described in this document for products manufactured on or after January 1, 2006. For complete warranty details on a specific Monogram model, visit Monogram.com or contact your nearest Monogram reseller, or call Monogram Factory Service, toll-free, 800-432-2737.

PRO RANGE

FOR THE PERIOD OF	MONOGRAM WILL REPLACE
Limited two-year warranty	For two years from date of original purchase, we will provide, free of charge, parts and service labor in your home to repair or replace any part of the appliance that fails because of a manufacturing defect.
Limited five-year warranty	For five years from the date of original purchase, we will provide, free of charge, replacement gas surface burners if they fail in normal household use. (The grill, griddle and oven burners are not included.) You pay for the service trip to your home and all service labor charges.
Limited lifetime warranty	For the lifetime of the gray porcelain enamel oven racks, we will provide, free of charge, replacement racks if they fail in normal household use. You pay for the service trip to your home and all service labor charges.

RANGETOP & COOKTOPS

FOR THE PERIOD OF	MONOGRAM WILL REPLACE
Limited two-year warranty	For two years from date of original purchase, we will provide, free of charge, parts and service labor in your home to repair or replace any part of the appliance that fails because of a manufacturing defect.
Limited five-year warranty	For five years from the date of original purchase, we will provide, free of charge, replacement gas surface burners if they fail in normal household use. (The grill and griddle are not included.) You pay for the service trip to your home and all service labor charges.

WALL OVENS

FOR THE PERIOD OF	MONOGRAM WILL REPLACE
Limited two-year warranty	For two years from date of original purchase, we will provide, free of charge, parts and service labor in your home to repair or replace any part of the appliance that fails because of a manufacturing defect.

ADVANTIUMS

FOR THE PERIOD OF	MONOGRAM WILL REPLACE
Limited two-year warranty	Any part of the oven which fails due to a defect in materials or workmanship. During this limited two-year warranty, Monogram will also provide, free of charge, all labor and related service costs to replace the defective part.
Limited five-year warranty	The magnetron tube, if the magnetron tube fails due to a defect in materials or workmanship. During this five-year limited warranty, you will be responsible for any labor or in-home service costs.

MICROWAVES

FOR THE PERIOD OF	MONOGRAM WILL REPLACE
Limited two-year warranty	For two years from the date of the original purchase, Monogram will replace any part of the microwave oven which fails due to a defect in materials or workmanship. During this limited two-year warranty, Monogram will also provide, free of charge, all labor and related service to replace the defective part.
Limited third through fifth-year warranty	For the third through fifth years from the date of the original purchase, Monogram will replace the magnetron tube, if the magnetron tube fails due to a defect in materials or workmanship. During this third through fifth-year limited warranty, you will be responsible for any labor or in-home service costs.

HOODS

FOR THE PERIOD OF	MONOGRAM WILL REPLACE
Limited two-year warranty	For two years from date of original purchase, we will provide, free of charge, parts and service labor in your home to repair or replace any part of the unit that fails because of a manufacturing defect.

WARMING DRAWER

FOR THE PERIOD OF	MONOGRAM WILL REPLACE
Limited two-year warranty	Any part of the warming drawer which fails due to a defect in materials or workmanship. During this limited two-year warranty, Monogram will provide, free of charge, all labor and in-home service to replace the defective part.

HEARTH OVEN

FOR THE PERIOD OF	MONOGRAM WILL REPLACE
Limited two-year warranty	For two years from date of original purchase, we will provide, free of charge, parts and service labor in your home to repair or replace any part of the oven that fails because of a manufacturing defect.

REFRIGERATION

FOR THE PERIOD OF	MONOGRAM WILL REPLACE
Limited two-year warranty	For two years from date of original purchase, we will provide, free of charge, parts and service labor in your home to repair or replace any part of the refrigerator or freezer that fails because of a manufacturing defect.
Limited five-year warranty	For five years from date of original purchase, we will provide, free of charge, parts and service labor in your home to repair or replace any part of the sealed refrigerating system (the compressor, condenser, evaporator and all connecting tubing) that fails because of a manufacturing defect.
Limited additional sixth-through twelfth-year warranty on the sealed system	For the sixth through twelfth year from the date of the original purchase, we will provide, free of charge, replacement parts for any part of the sealed refrigerating system (the compressor, condenser, evaporator and all connecting tubing) that fails because of a manufacturing defect. You pay for the service trip to your home and for service labor charges.
Limited thirty-day warranty on water filter cartridge (Water filter, if included)	From the date of the original purchase we will provide, free of charge, replacement parts for any part of the water filter cartridge that fails because of a manufacturing defect. During this limited thirty-day warranty, we will also provide, free of charge, a replacement water filter cartridge.

UNDERCOUNTER

FOR THE PERIOD OF	MONOGRAM WILL REPLACE
Limited two-year warranty	For two years from date of original purchase, we will provide, free of charge, parts and service labor in your home to repair or replace any part of the unit that fails because of a manufacturing defect.
Limited third through fifth-year warranty	For the third through fifth years from date of original purchase, we will provide, free of charge, parts and service labor in your home to repair or replace any part of the sealed refrigerating system (the compressor, condenser, evaporator and all connecting tubing) that fails because of a manufacturing defect.

ICEMAKERS

FOR THE PERIOD OF	MONOGRAM WILL REPLACE
One Year Warranty	Any part of the ice machine which fails due to a defect in materials or workmanship. During the limited one-year warranty, GE Appliances will also provide, free of charge, all labor and related service to replace the defective part.
Five Year Warranty	Any part of the sealed refrigeration system. During the limited five-year sealed refrigerating system warranty, GE Appliances will also provide, free of charge, all labor and related service to replace the defective part in the sealed refrigerating system.

DISHWASHER

FOR THE PERIOD OF	MONOGRAM WILL REPLACE
Limited two-year warranty	Any part of the dishwasher which fails due to a defect in materials or workmanship. During this limited two-year warranty, Monogram will also provide, free of charge, all labor and in-home service to replace the defective part.
Three to Five Year Warranty	The dishwasher rack and/or the electronic control module, if these should fail due to a defect in materials or workmanship. During this three to five year limited warranty, you will be responsible for any labor or in-home service costs.
Limited lifetime warranty	The stainless steel tub or door liner, if it fails to contain water due to a defect in materials or workmanship. During this limited lifetime warranty, Monogram will also provide, free of charge, all labor and in-home service to replace the defective part.

EXCLUSION OF IMPLIED WARRANTIES – Your sole and exclusive remedy is product repair as provided in this Limited Warranty. Any implied warranties, including the implied warranties of merchantability or fitness for a particular purpose, are limited to one year or the shortest period allowed by law.

This warranty is extended to the original purchaser and any succeeding owner for products purchased for home use within the USA. In Alaska, the One-Year Warranty excludes the cost of shipping, or service calls to your home. Some states do not allow the exclusion or limitation of incidental or consequential damages. This warranty gives you specific legal rights, and you may also have other rights which vary from state to state. To know what your legal rights are, consult your local or state consumer affairs office or your state's Attorney General.

Limited Warranty Information

(SEE WRITTEN WARRANTY FOR COMPLETE DETAILS)



The condensed list below is a convenient overview of the written warranties offered on various Café™ appliances described in this document for products manufactured on or after January 1, 2006. For complete warranty details on a specific Café model, visit Café.com or contact your nearest Café reseller, or call Café Factory Service, toll free, 800-432-2737.

Refrigerators, Wine and Beverage Centers, 50 lb./Refrigerator Ice Makers

ALL CAFÉ MODELS

For the period of	Café will replace
One year From the date of the original purchase	Any part in the refrigerator which fails due to a defect in materials or workmanship. During this limited one-year warranty , Café will provide, free of charge , all labor and related service costs to replace the defective part.
Five years From the date of the original purchase	Any part of the sealed refrigerating system (the compressor, condenser, evaporator and all connecting tubing) which fails due to a defect in materials or workmanship. During this limited five-year sealed refrigerating system warranty , Café will also provide, free of charge , all labor and related service costs to replace the defective part.

Ice Makers

FOR REFRIGERATORS

For the period of	Café will replace
One year From the date of the original purchase	Any part in the ice maker which fails due to a defect in materials or workmanship. During this limited one-year warranty , Café will provide, free of charge , all labor and related service costs to replace the defective part.

Ranges, Cooktops, Wall Ovens, Warming Drawers and Hoods

ALL CAFÉ MODELS

For the period of	Café will replace
One year From the date of the original purchase	Any part in the cooking product which fails due to a defect in materials or workmanship. During this limited one-year warranty Café will provide, free of charge , all labor and related service costs to replace the defective part.

Speedcook Ovens with Advantium® Technology

ALL CAFÉ MODELS

For the period of	Café will choose to replace or service
One year From the date of the original purchase	Any part of the oven which fails due to a defect in materials or workmanship. During this limited one-year warranty , Café will provide, free of charge , all labor and related service costs to replace the defective part.
Five years From the date of the original purchase	The magnetron tube , if the magnetron tube fails due to a defect in the materials or workmanship. During this five-year limited warranty , you will be responsible for any labor or in-home service costs.

Over-The-Range, Drawer, and Countertop Microwave Ovens

ALL CAFÉ MODELS

For the period of	Café will choose to replace or service
One year From the date of the original purchase	Any part in the microwave which fails due to a defect in materials or workmanship. During this limited one-year warranty , Café will also provide, free of charge , all labor and in-home service costs to replace the defective part.
Five years From the date of the original purchase	The magnetron tube , if the magnetron tube fails due to a defect in the materials or workmanship. During this five-year limited warranty , you will be responsible for any labor or in-home service costs.

Dishwashers and Compactors

ALL CAFÉ MODELS

For the period of	Café will replace
One year From the date of the original purchase	Any part in the dishwasher which fails due to a defect in materials or workmanship. During this limited one-year warranty , Café will provide, free of charge , all labor and related service costs to replace the defective part.

Parts and Accessories

For the period of	Café will replace
One year From the date of the original purchase	Any part or accessory which fails due to a defect in materials or workmanship. During this limited one-year warranty , Café will provide, free of charge , all labor and related service costs to replace the defective part or accessory.

For each product listed

What Café will not cover:

- Service trips to your home to teach you how to use the product
- Improper installation
- Replacement of house fuses or resetting of circuit breakers
- Failure of the product if it is abused, misused or used for anything other than the intended purpose or used commercially
- Damage to product caused by accident, fire, floods or acts of God
- Incidental or consequential damage caused by possible defects with this appliance

EXCLUSION OF IMPLIED WARRANTIES - Your sole and exclusive remedy is product repair as provided in this Limited Warranty. Any implied warranties, including the implied warranties of merchantability or fitness for a particular purpose, are limited to one year or the shortest period allowed by law.

This warranty is extended to the original purchaser and any succeeding owner for products purchased for home use within the USA. In Alaska, the One-Year Warranty excludes the cost of shipping, or service calls to your home. Some states do not allow the exclusion or limitation of incidental or consequential damages. This warranty gives you specific legal rights, and you may also have other rights which vary from state to state. To know what your legal rights are, consult your local or state consumer affairs office or your state's Attorney General.

LIMITED WARRANTY INFORMATION

(SEE WRITTEN WARRANTY FOR COMPLETE DETAILS.)



The condensed list below is a convenient overview of the written warranties offered on various GE Appliances & GE Profile appliances described in this document for products manufactured on or after January 1, 2006. For complete warranty details on a specific GE Appliances or GE Profile model, visit geappliances.com, contact your nearest GE Appliances/GE Profile reseller, or call GE Appliances Factory Service, 800.GE.CARES (800-432-2737).

REFRIGERATORS, FREEZERS, WINE AND BEVERAGE CENTERS

For the period of	GE Appliances will replace
One year From the date of the original purchase	Any part in the refrigerator which fails due to a defect in materials or workmanship. During this limited one-year warranty , GE Appliances will provide, free of charge , all labor and related service costs to replace the defective part.
Five years From the date of the original purchase (GE Profile models ONLY)	Any part of the sealed refrigerating system (the compressor, condenser, evaporator and all connecting tubing) which fails due to a defect in materials or workmanship. During this limited five-year sealed refrigerating system warranty , GE Appliances will also provide, free of charge , all labor and related service costs to replace the defective part on GE Profile™ appliances only.

ICEMAKERS

For Refrigerators

For the period of	GE Appliances will replace
One year From the date of the original purchase	Any part in the icemaker which fails due to a defect in materials or workmanship. During this limited one-year warranty , GE Appliances will provide, free of charge , all labor and related service costs to replace the defective part.

WATER FILTERS

For the period of	GE Appliances will replace
30 days From the date of the original purchase	Any part of the water filter cartridge which fails due to a defect in materials or workmanship during this limited thirty-day warranty .*

RANGES, COOKTOPS, WALL OVENS, WARMING DRAWERS AND HOODS

For the period of	GE Appliances will replace
One year From the date of the original purchase	Any part in the cooking product which fails due to a defect in materials or workmanship. During this limited one-year warranty GE Appliances will provide, free of charge , all labor and related service costs to replace the defective part.

SPEEDCOOK FIVE-IN-ONE OVENS WITH ADVANTIUM® TECHNOLOGY

For the period of	GE Appliances will choose to replace or service
One year From the date of the original purchase	Any part of the oven which fails due to a defect in materials or workmanship. During this limited one-year warranty , GE Appliances will provide, free of charge , all labor and related services costs to replace the defective part.
Five years From the date of the original purchase	The magnetron tube , if the magnetron tube fails due to a defect in the materials or workmanship. During this five-year limited warranty , you will be responsible for any labor or in-home service costs.

OVER-THE RANGE AND COUNTERTOP MICROWAVES

For the period of	GE Appliances will choose to replace or service
One year From the date of the original purchase	In the event of service , GE Appliances will provide any part of the microwave which fails due to a defect in materials or workmanship. During this limited one-year warranty , GE Appliances will also provide, free of charge , all labor and related service costs to replace the defective part when the unit is serviced.

DISHWASHERS AND COMPACTORS

For the period of	GE Appliances will replace
One year From the date of the original purchase	Any part in the dishwasher or compactor which fails due to a defect in materials or workmanship. During this limited one-year warranty , GE Appliances will provide, free of charge , all labor and related service costs to replace the defective part.

DISPOSERS

For the period of	GE Appliances will replace
One year From the date of the original purchase	Models GFC320 and GFC325: The entire disposer if there is a defect in materials or workmanship relating to functional parts only (appearance parts are excluded). During this limited one-year warranty , GE Appliances will also provide, free of charge , all labor charges related to replacing the original disposer along with the replacement disposer within the first year.
Additional one year From the date of the original purchase	Models GFC520V, GFC525V: If there is a defect in materials or workmanship relating to functional parts only (appearance parts are excluded). During this one-year extended limited warranty period , you will be responsible for all installation charges related to the replacement disposer.
Additional two years From the date of the original purchase	Models GFC530V, GFC535V: If there is a defect in materials or workmanship relating to functional parts only (appearance parts are excluded). During this two-year extended limited warranty period , you will be responsible for all installation charges related to the replacement disposer.
Additional four years From the date of the original purchase	Models GFC720V, GFB760V: If there is a defect in materials or workmanship relating to functional parts only (appearance parts are excluded). During this four-year extended limited warranty period , you will be responsible for all installation charges related to the replacement disposer.
Additional six years From the date of the original purchase	Model GFC1020V: If there is a defect in materials or workmanship relating to functional parts only (appearance parts are excluded). During this six-year extended limited warranty period , you will be responsible for all installation charges related to the replacement disposer.
Three years From the date of the original purchase	Model GREEN05P: The entire disposer if there is a defect in materials or workmanship relating to functional parts only (appearance parts are excluded). During this limited three-year warranty , GE Appliances will also provide, free of charge , all labor charges related to replacing the original disposer along with the replacement disposer within the first year.

*If your GE Appliances part fails because of a manufacturing defect within thirty days from the date of original purchase for use, we will give you a new or, at our option, a rebuilt part without charge. Return the defective part to the parts supplier from whom it was purchased together with a copy of the "proof of purchase" for the part. If the part is defective and shows no signs of abuse, it will be exchanged. The warranty does not cover the failure of parts which are damaged while in your possession, are abused, or have been installed improperly. It does not cover the cost of returning the part to the supplier from whom it was purchased nor does it cover the cost of labor to remove or install it to diagnose the fault. It does not cover parts used in products in commercial use except in the case of air conditioning equipment. In no event shall GE Appliances be liable for consequential damages. Warrantor: GE Appliances

GE Appliances has a policy of continuous improvement of its products and reserves the right to change materials and specifications without notice.

(continued on next page)

ELECTRIC WATER HEATER

For the period of	GE Appliances will replace
One year From the date of the original purchase	Any part in the Water Heater which fails due to a defect in materials or workmanship. During this limited one-year warranty , GE Appliances will reimburse registered service providers, or will reimburse consumers for documented out of pocket costs for parts and/or labor for professional service at a predetermined rate as found on the GE Appliances Website GEAppliances.com/water heater , unless service provided to replace defective parts is determined to be a result of improper installation or maintenance.
Second through Eighth, Tenth or Twelfth Year From the date of the original purchase	Any part of the Water Heater which fails due to a defect in materials or workmanship. During this limited second through the end of the warranty period , labor and related service to replace the defective part are not included. *Warranty is based on the 6th and 7th digit of model number located on rating plate (e.g.: GE50T08BAM has a part warranty of 8 years).

TANKLESS ELECTRIC WATER HEATERS

For the period of	GE Appliances will replace
Five years From the date of the original purchase	We will replace: The entire water heater if there is a defect in materials or workmanship relating to functional parts only. During this warranty period , labor and related service to install the new water heater or remove the defective water heater is not covered under this warranty . The replacement unit is warranted for the remainder of your water heater's original five-year warranty period . The replacement unit may either be a new unit or a refurbished unit.

ATMOSPHERIC GAS WATER HEATER

For the period of	GE Appliances will replace
One year From the date of the original purchase	We will replace: Any factory specified part of the water heater which fails due to a defect in materials or workmanship. During this limited one-year warranty , we will also provide, free of charge, all labor and related service to replace the defective part. For the period of second through eighth, tenth or twelfth year from the date of the original purchase. We will replace: Any part of the water heater which fails due to a defect in materials or workmanship. During this limited second through the end of the warranty period, labor and related service to replace the defective part are not included. *Warranty is based on the 6th and 7th digit of model number located on rating plate (e.g.: GE50T08BAM has a part warranty of 8 years).

SOLAR WATER HEATER

For the period of	GE Appliances will replace
One year From the date of the original purchase	Any part in the Water Heater which fails due to a defect in materials or workmanship. During this limited one-year warranty , GE Appliances will reimburse registered service providers, or will reimburse consumers for documented out-of-pocket costs for parts and/or labor for professional service at a predetermined rate as found on the GE Appliances Website GEAppliances.com/water heater , unless service provided to replace defective parts is determined to be a result of improper installation or maintenance.
Second through Fifth Year From the date of the original purchase	Any part in the Water Heater which fails due to a defect in materials or workmanship. During this limited second through year five warranty period , labor and related service to replace the defective part are not included.
Sixth through Tenth Year From the date of the original purchase	50% of the cost of any part , of the water heater which fails due to defect in materials or workmanship. During this sixth through the end of the warranty period , labor and related service to replace the defective part are not included. Warranty is based on the 6th and 7th digit of model number located on rating plate (e.g.: GE50T10BAM has a part warranty of 10 years).

WATER SOFTENERS

For the period of	GE Appliances will replace
One year From the date of the original purchase	Any part of the Water Softening System which fails due to a defect in materials or workmanship. During this limited one-year warranty , GE Appliances will provide, free of charge , all labor and related service costs to replace the defective part.
Second through third year From the date of the original purchase	Electronic Monitor , if the Electronic Monitor fails due to a defect in materials or workmanship. During this additional two-year limited warranty , you will be responsible for any labor and related service costs.
Second through tenth year From the date of the original purchase	Cabinet (Brine Tank) and Resin Tank , if either of these parts fail due to a defect in materials or workmanship. During this additional nine-year limited warranty , you will be responsible for any labor and related service costs.

WASHERS

For the period of	GE Appliances will replace
One year From the date of the original purchase	Any part in the washer which fails due to a defect in materials or workmanship. During this limited one-year warranty , GE Appliances will provide, free of charge , all labor and related service costs to replace the defective part.
Ten years From the date of the original purchase	Models GFW850, GTW840/845, GTW720/725, GTW680/685, GFW650, GFW550 and GFW510: The motor , if it should fail due to a defect in materials or workmanship. During this additional nine-year limited warranty , you will be responsible for any labor and related service costs.

TOP LOAD WASHERS

For the period of	GE Appliances will replace
One year From the date of the original purchase	Any part of the washer which fails due to a defect in materials or workmanship. During this limited one-year warranty , we will also provide, free of charge , all labor and related service to replace the defective part.
Warranties for GTW525 model only:	
Five years From the date of the original purchase	Any part of the washer which fails due to a defect in materials or workmanship. During this limited five-year warranty , we will also provide, free of charge , all labor and related service to replace the defective part.
Ten years From the date of the original purchase	The motor , if it should fail due to a defect in materials or workmanship. During this additional nine-year limited warranty , you will be responsible for any labor and related service costs.
Lifetime of Product From the date of the original purchase	The stainless steel basket , if it should fail due to rust or corrosion of the stainless steel. During this additional LIFETIME limited warranty you will be responsible for any labor and related service costs.

DRYERS

For the period of	GE Appliances will replace
One year From the date of the original purchase	Any part in the dryer which fails due to a defect in materials or workmanship. During this limited one-year warranty , GE Appliances will provide, free of charge , all labor and related service costs to replace the defective part.

REVERSE OSMOSIS FILTRATION SYSTEMS

For the period of	GE Appliances will replace
One year From the date of the original purchase	Any part of the Reverse Osmosis Filtration System (excluding filters) which fails due to a defect in materials or workmanship. During this limited one-year warranty , GE Appliances will provide, free of charge , all labor and related service costs to replace the defective part.

LIMITED WARRANTY INFORMATION (continued)
(SEE WRITTEN WARRANTY FOR COMPLETE DETAILS.)



DUAL-STAGE AND SINGLE-STAGE WATER FILTRATION AND WHOLE HOUSE FILTRATION

For the period of	GE Appliances will replace
One year From the date of the original purchase	Any part of the Water Filtration System (excluding filters) which fails due to a defect in materials or workmanship. During this limited one-year warranty , GE Appliances will provide, free of charge , all labor and related service costs to replace the defective part.

DUAL-STAGE AND SINGLE-STAGE WATER FILTRATION AND WHOLE HOUSE FILTRATION

All GE models starting with GX

For the period of	GE Appliances will replace
One year From the date of the original purchase	Any part of the Water Filtration System (excluding filters) which fails due to a defect in materials or workmanship. During this limited one-year warranty , you will be responsible for any labor and related service costs.

DUAL-STAGE AND SINGLE-STAGE WATER FILTRATION AND WHOLE HOUSE FILTRATION

GE models: UNFCTFBL, UCRING, UCWRENCH, HHRING & HHWRNCH

For the period of	GE Appliances will replace
30 days From the date of the original purchase	Any part of the water filtration accessory that fails due to a defect in materials or workmanship. During this limited 30-day warranty , you will be responsible for any labor and related service costs.

AIR CONDITIONERS

Window

For the period of	GE Appliances will replace
One year From the date of the original purchase	Replacement, repair, or refund of the original retail price for any product which fails due to a defect in materials or workmanship. If the unit is exchanged, the replacement unit is warranted for the remainder of your product's original one-year warranty period. GE Appliances will, at its sole discretion, replace the product with a product of the same or comparable functionality and quality or refund the original retail price.

DEHUMIDIFIERS

For the period of	GE Appliances will replace
One year From the date of the original purchase	Replacement, repair, or refund of the original retail price for any product which fails due to a defect in materials or workmanship . If the unit is exchanged, the replacement unit is warranted for the remainder of your product's original one-year warranty period. GE Appliances will, at its sole discretion, replace the product with a product of the same or comparable functionality and quality or refund the original retail price.

AIR CONDITIONERS

24" Through-the-Wall

For the period of	GE Appliances will replace
Two years From the date of the original purchase	Any part of the air conditioner which fails due to a defect in materials or workmanship. During this limited one-year warranty , GE Appliances will provide, free of charge , all labor and related service costs to replace the defective part.

AIR CONDITIONERS

Zoneline® and Vertical Zoneline

For the period of	GE Appliances will replace
One year From the date of the original purchase	Any part of the air conditioner which fails due to a defect in materials or workmanship. During this limited one-year warranty , GE Appliances will provide, free of charge , all labor and related service costs to replace the defective part.
Five years From the date of the original purchase	Sealed Refrigerating System , if any part of the Makeup Air Module or Sealed Refrigerating System (the compressor, condenser, evaporator, and all connecting tubing) should fail due to a defect in materials or workmanship. During this limited five-year warranty , GE Appliances will provide, free of charge , all labor and related service costs to replace the defective part.
Second through fifth year (Zoneline only) From the date of the original purchase	Fan Motors, Switches, Thermostat, Heater, Heater Protectors, Compressor Overload, Solenoids, Circuit Boards, Auxiliary Controls, Thermistors, Frost Controls, Freeze Sentinel, ICR Pump, Capacitors, Varistors and Indoor Blower Bearing , if any of these parts should fail due to a defect in materials or workmanship. During this additional four-year limited warranty , you will be responsible for any labor and related service costs.
Second through fifth year (vertical Zoneline only) From the date of the original purchase	Fan Motors, Switches, Thermostat, Heater, Heater Protectors, Compressor Overload, Solenoids, Circuit Boards, Auxiliary Controls, Thermistors, Frost Controls, Freeze Sentinel , if any of these parts should fail due to a defect in materials or workmanship. During this additional four-year limited warranty , the customer will be responsible for any labor and related service costs.

AIR CONDITIONERS

26" Built-In

For the period of	GE Appliances will replace
Two years From the date of the original purchase	Any part in the air conditioner which fails due to a defect in materials or workmanship. During this limited two-year warranty , GE Appliances will provide, free of charge , all labor and related service costs to replace the defective part.
Five years From the date of the original purchase	Any part of the Sealed Refrigerating System (compressor, condenser, evaporator, reversing valve and all connecting tubing) which fails due to a defect in materials or workmanship. During this three-year additional warranty , GE Appliances will provide, free of charge , all labor and related service costs to replace the defective part.

PORTABLE AIR CONDITIONER UNITS

For the period of	GE Appliances will replace
One year From the date of the original purchase	Replacement, repair or refund of the original retail price for any product which fails due to a defect in materials or workmanship . If the unit is exchanged, the replacement unit is warranted for the remainder of your product's original one-year warranty period. GE will, at its sole discretion, replace the product with a product of the same or comparable functionality and quality or refund the original retail price .



PARTS AND ACCESSORIES

For the period of	GE Appliances will replace
One year From the date of the original purchase	If your GE Appliances part fails because of a manufacturing defect within one year from the date of original purchase , we will provide a new or, at our option, rebuilt part without charge. Return the defective part to the vendor from whom it was purchased with a copy of the "proof of purchase." If the part is defective it will be exchanged. This warranty does not cover parts which are improperly installed, damaged, abused or used for other than the intended purpose. It does not include cost of returning the part to the vendor from which it was purchased, labor to remove, install or diagnose the failure, parts used in commercial applications, incidental or consequential damage caused by possible defects with the parts. Excludes water filters which offer 30-day warranty.

FOR EACH PRODUCT LISTED

What GE Appliances will not cover:
<ul style="list-style-type: none"> ■ Service trips to your home to teach you how to use the product. ■ Improper installation. ■ Replacement of house fuses or resetting of circuit breakers. ■ Failure of the product if it is abused, misused or used for anything other than the intended purpose or used commercially. ■ Damage to product caused by accident, fire, floods or acts of God. ■ Incidental or consequential damage caused by possible defects with this appliance.

EXCLUSION OF IMPLIED WARRANTIES - Your sole and exclusive remedy is product repair as provided in this Limited Warranty. Any implied warranties, including the implied warranties of merchantability or fitness for a particular purpose, are limited to one year or the shortest period allowed by law.

This warranty is extended to the original purchaser and any succeeding owner for products purchased for home use within the USA. In Alaska, the One-Year Warranty excludes the cost of shipping, or service calls to your home. Some states do not allow the exclusion or limitation of incidental or consequential damages. This warranty gives you specific legal rights, and you may also have other rights which vary from state to state. To know what your legal rights are, consult your local or state consumer affairs office or your state's Attorney General.

LIMITED WARRANTY INFORMATION

(SEE WRITTEN WARRANTY FOR COMPLETE DETAILS.)



The condensed list below is a convenient overview of the written warranties offered on various Haier appliances described in this document for products manufactured on or after January 1, 2006. For complete warranty details on a specific Haier model, visit Haierappliances.com, contact your nearest Haier supplier, or call Haier Customer Care, toll-free, 1-877-337-3639.

REFRIGERATION

REFRIGERATORS

ALL HAIER MODELS

For the period of	Haier will replace
One year from the date of the original purchase	Any part in the refrigerator which fails due to a defect in materials or workmanship. During the limited one-year warranty , Haier will provide, free of charge , all labor and related service costs to replace the defective part.

COOKING

RANGES, COOKTOPS, WALL OVENS, AND HOODS

ALL HAIER MODELS

For the period of	Haier will replace
One year from the date of the original purchase	Any part in the cooking product which fails due to a defect in materials or workmanship. During the limited one-year warranty , Haier will provide, free of charge , all labor and related service costs to replace the defective part.

OVER-THE-RANGE MICROWAVE OVEN

ALL HAIER MODELS

For the period of	Haier will choose to repair or replace
One year from the date of the original purchase	Any part of the microwave oven which fails due to a defect in materials or workmanship. During this limited one-year warranty , Haier will also provide, free of charge , all labor and related service costs to replace the defective part.

DISHWASHERS

DISHWASHER

ALL HAIER MODELS

For the period of	Haier will replace
One year from the date of the original purchase	Any part in the dishwasher which fails due to a defect in materials or workmanship. During the one-year warranty , Haier will provide, free of charge , all labor and related service costs to replace the defective part.

CLOTHES CARE

COMPACT DRYER

ALL HAIER MODELS

For the period of	Haier will replace
One year from the date of the original purchase	Any part in the dryer which fails due to a defect in materials or workmanship. During the one-year warranty , Haier will provide, free of charge , all labor and related service costs to replace the defective part.

WASHER/DRYER COMBINATION

ALL HAIER MODELS

For the period of	Haier will replace
One year from the date of the original purchase	Any part in the washer/dryer which fails due to a defect in materials or workmanship. During the one-year warranty , Haier will provide, free of charge , all labor and related service costs to replace the defective part.
Five years from the date of the original purchase	Any part of the cabinet assembly which fails due to a defect in materials or workmanship. During the five-year warranty , Haier will provide, free of charge , the cabinet assembly should the cabinet rust through. You will be responsible for any labor and related service costs.
Ten years from the date of the original purchase	The inner stainless steel drum if it should fail due to a defect in materials or workmanship. During the ten-year limited warranty , Haier will provide, free of charge , the inner stainless steel wash tub. You will be responsible for any labor and related service costs.

COMFORT PRODUCTS

AIR CONDITIONERS

WINDOW

For the period of	Haier will replace
One year from the date of the original purchase	Replacement, repair, or refund of the original retail price for any product which fails due to a defect in materials or workmanship. If the unit is exchanged, the replacement unit is warranted for the remainder of your product's original one-year warranty period. GE Appliances will, at its sole discretion, replace the product with a product of the same or comparable functionality and quality or refund the original retail price.

THROUGH-THE-WALL

For the period of	Haier will replace
One year from the date of the original purchase	Replacement, repair, or refund of the original retail price for any product which fails due to a defect in materials or workmanship. If the unit is exchanged, the replacement unit is warranted for the remainder of your product's original one-year warranty period. GE Appliances will, at its sole discretion, replace the product with a product of the same or comparable functionality and quality or refund the original retail price.

PORTABLE

For the period of	Haier will replace
One year from the date of the original purchase	Replacement, repair, or refund of the original retail price for any product which fails due to a defect in materials or workmanship. If the unit is exchanged, the replacement unit is warranted for the remainder of your product's original one-year warranty period. GE Appliances will, at its sole discretion, replace the product with a product of the same or comparable functionality and quality or refund the original retail price.

DEHUMIDIFIERS

For the period of	Haier will replace
One year from the date of the original purchase	Replacement, repair, or refund of the original retail price for any product which fails due to a defect in materials or workmanship. If the unit is exchanged, the replacement unit is warranted for the remainder of your product's original one-year warranty period. GE Appliances will, at its sole discretion, replace the product with a product of the same or comparable functionality and quality or refund the original retail price.

LIMITED WARRANTY INFORMATION

(SEE WRITTEN WARRANTY FOR COMPLETE DETAILS.)



The condensed list below is a convenient overview of the written warranties offered on various Hotpoint® appliances described in this document for products manufactured on or after January 1, 2006. For complete warranty details on a specific appliance model, visit hotpoint.com, contact your nearest Hotpoint appliance reseller. Hotpoint is backed by GE Appliances Service and serviced by GE Appliance technicians. You can call GE Appliance Service at 1-800-GECares (1-800-432-2737)

REFRIGERATORS

FOR THE PERIOD OF	HOTPOINT WILL REPLACE
One year From the date of the original purchase	Any part in the refrigerator which fails due to a defect in materials or workmanship. During this limited one-year warranty, Hotpoint will provide, free of charge, all labor and related service costs to replace the defective part.

RANGES

FOR THE PERIOD OF	HOTPOINT WILL REPLACE
One year From the date of the original purchase	Any part in the cooking product which fails due to a defect in materials or workmanship. During this limited one-year warranty, Hotpoint will provide, free of charge, all labor and related service costs to replace the defective part.

MICROWAVE OVENS

FOR THE PERIOD OF	HOTPOINT WILL REPLACE
One year From the date of the original purchase	Any part in the microwave which fails due to a defect in materials or workmanship. During this limited one-year warranty, Hotpoint will provide, free of charge, all labor and related service costs to replace the defective part.

DISHWASHERS

FOR THE PERIOD OF	HOTPOINT WILL REPLACE
One year From the date of the original purchase	Any part in the dishwasher which fails due to a defect in materials or workmanship. During this limited one-year warranty, Hotpoint will provide, free of charge, all labor and related service costs to replace the defective part.

WASHERS

FOR THE PERIOD OF	HOTPOINT WILL REPLACE
One year From the date of the original purchase	Any part in the washer which fails due to a defect in materials or workmanship. During this limited one-year warranty, Hotpoint will provide, free of charge, all labor and related service costs to replace the defective part.

DRYERS

FOR THE PERIOD OF	HOTPOINT WILL REPLACE
One year From the date of the original purchase	Any part in the dryer which fails due to a defect in materials or workmanship. During this limited one-year warranty, Hotpoint will provide, free of charge, all labor and related service costs to replace the defective part.

COMFORT PRODUCTS

FOR THE PERIOD OF	HOTPOINT WILL REPLACE
One year From the date of the original purchase	Any part of the air conditioner which fails due to a defect in materials or workmanship. During this limited one-year warranty, Hotpoint will provide, free of charge, all labor and related service costs to replace the defective part.
Five years From the date of the original purchase	Any part of the sealed refrigerating system (the compressor, condenser, evaporator and all connecting tubing) which fails due to a defect in materials or workmanship. During this limited five-year warranty, Hotpoint will provide, free of charge, all labor and related service costs to replace the defective part.

PARTS AND ACCESSORIES

FOR THE PERIOD OF	HOTPOINT WILL REPLACE
One year From the date of the original purchase	If your GEA part fails because of a manufacturing defect within one year from the date of original purchase, we will provide a new or, at our option, rebuilt part without charge. Return the defective part to the vendor from whom it was purchased with a copy of the "proof of purchase." If the part is defective it will be exchanged. This warranty does not cover parts which are improperly installed, damaged, abused or used for other than the intended purpose. It does not include cost of returning the part to the vendor from which it was purchased, labor to remove, install or diagnose the failure, parts used in commercial applications, incidental or consequential damage caused by possible defects with the parts.

EXCLUSION OF IMPLIED WARRANTIES — Your sole and exclusive remedy is product repair as provided in this Limited Warranty. Any implied warranties, including the implied warranties of merchantability or fitness for a particular purpose, are limited to one year or the shortest period allowed by law.

GE is a trademark of the General Electric Company.
Manufactured under trademark license.

GE Appliances has a policy of continuous improvement
of its products and reserves the right to change
materials and specifications without notice.